



ORiNOCO AP-600

User Guide



Take your network further

Copyright

© 2003 Proxim Corporation. All rights reserved. Covered by one or more of the following U.S. patents: 5,231,634; 5,875,179; 6,006,090; 5,809,060; 6,075,812; 5,077,753. This user's guide and the software described in it are copyrighted with all rights reserved. No part of this publication may be reproduced, transmitted, transcribed, stored in a retrieval system, or translated into any language in any form by any means without the written permission of Proxim Corporation.

Trademarks

ORiNOCO is a registered trademark, and 2X, Proxim, and the Proxim logo are trademarks of Proxim Corporation. All other trademarks mentioned herein are the property of their respective owners.

Contents

- 1 Introduction 11**
 - Introducing the AP-600 11
 - Document Conventions 11
 - The Product Package 12
 - System Requirements 12
 - IEEE 802.11 Specifications 12
 - Wireless Networking Concepts 13
 - Guidelines for Roaming 13
 - Management and Monitoring Capabilities 14
 - HTTP Interface 14
 - Command Line Interface 14
 - SNMP Management 14
 - Wireless Network Manager 15
 - Active Ethernet 15
 - Software Features 15
- 2 Installation & Basic Configuration 18**
 - Prerequisites 18
 - Installation 19
 - Initialization 23
 - ScanTool 23
 - ScanTool Instructions 23
 - Setup Wizard 26
 - Setup Wizard Instructions 26
 - Download the Latest Software 29
 - Setup your TFTP Server 29
 - Download Updates from your TFTP Server using the Web Interface 29
 - Download Updates from your TFTP Server using the CLI Interface 30
 - Additional Hardware Features 30
 - Mounting Options 30
 - Desktop Mount 30
 - Wall Mount 30
 - Ceiling Mount 32

Contents



- Installing the AP-600 in a Plenum 33
- Kensington Security Slot 33
- LED Indicators 34
- 3 Status Information 36**
- Logging into the HTTP Interface 36
- System Status 37
- 4 Advanced Configuration 38**
- Configuring the AP-600 Using the HTTP Interface 38
- System 40
- Network 40
 - IP Configuration 40
 - DHCP Server 41
 - Link Integrity 42
- Interfaces 43
 - Wireless (AP-600a) 43
 - Dynamic Frequency Selection (DFS) 45
 - RTS/CTS Medium Reservation 45
 - Wireless (AP-600b) 45
 - Distance Between APs 47
 - Multicast Rate 48
 - Wireless Distribution System (WDS) 49
 - Ethernet 51
- Management 52
 - Passwords 52
 - IP Access Table 52
 - Services 53
- Filtering 54
 - Ethernet Protocol 54
 - Static MAC 55
 - Static MAC Filter Examples 56
 - Advanced 57
 - TCP/UDP Port 58
 - Adding TCP/UDP Port Filters 58
 - Editing TCP/UDP Port Filters 59
- Alarms 59
 - Groups 59
 - Alarm Host Table 59
 - Syslog 60
 - Setting Syslog Event Notifications 60

Contents

Configuring Syslog Event Notifications	60
Bridge	61
Spanning Tree	61
Storm Threshold	61
Intra BSS	62
Packet Forwarding	62
Configuring Interfaces for Packet Forwarding	62
Security	62
MAC Access	63
WEP Encryption	64
802.1x	65
Authentication Process	65
Configuring Security Settings	66
802.1x Security	66
Mixed Mode (802.1x and WEP Encryption)	67
RADIUS	68
MAC Access Control Via RADIUS Authentication	68
RADIUS Authentication with 802.1x	70
RADIUS Accounting	70
Session Length	70
Configuring RADIUS Accounting	71
5 Monitor Information	72
Logging into the HTTP Interface	72
Version	74
ICMP	75
IP/ARP Table	75
Learn Table	76
IAPP	76
RADIUS	77
Interfaces	78
Link Test (AP-600b Only)	79
6 Commands	81
Logging into the HTTP Interface	81
Download	83
Upload	83
Reboot	84
Reset	85

- Help Link 85
- 7 Troubleshooting.....86**
- Troubleshooting Concepts 86
- Symptoms and Solutions 87
- Connectivity Issues 87
- AP-600 Unit Will Not Boot - No LED Activity 87
- Serial Link Does Not Work 87
- Ethernet Link Does Not Work 87
- Basic Software Setup and Configuration Problems..... 87
- Lost AP-600, Telnet, or SNMP Password..... 87
- Client Computer Cannot Connect..... 87
- AP-600 Has Incorrect IP Address..... 87
- HTTP (browser) or Telnet Interface Does Not Work..... 88
- HTML Help Files Do Not Appear 88
- Telnet CLI Does Not Work 88
- TFTP Server Does Not Work 88
- Client Connection Problems 89
- Client Software Finds No Connection..... 89
- Client PC Card Does Not Work 89
- Intermittent Loss of Connection 89
- Client Does Not Receive an IP Address - Cannot Connect to Internet 89
- Active Ethernet (AE) 89
- The AP-600 Does Not Work 89
- There Is No Data Link..... 89
- “Overload” Indications 90
- Recovery Procedures 90
- Reset to Factory Default Procedure 90
- Forced Reload Procedure 91
- Download a New Image Using ScanTool 91
- Download a New Image Using the Bootloader CLI 92
- Setting IP Address using Serial Port and Normal CLI 93
- Hardware and Software Requirements..... 93
- Attaching the Serial Port Cable..... 93
- Initializing the IP Address using CLI..... 93
- System Alarms (Traps) 95
- Security Alarms 95
- Wireless Interface Card Alarms..... 95
- Operational Alarms 95
- FLASH Memory Alarms..... 95
- TFTP Alarms 95

Contents

Image Alarms	95
Standard MIB-II (RFC 1213) Alarms	95
Bridge MIB (RFC 1493) Alarms	96
Related Applications	96
RADIUS Authentication Server	96
TFTP Server	96
A Command Line Interface (CLI)	97
General Notes	97
Prerequisite Skills and Knowledge	97
Notation Conventions	97
Important Terminology	97
Navigation and Special Keys	98
CLI Error Messages	98
Command Line Interface (CLI) Variations	98
Bootloader CLI	99
CLI Command Types	100
Operational CLI Commands	100
? (List Commands)	100
done, exit, quit	102
download	102
help	102
history	103
passwd	103
reboot	103
search	103
upload	104
Parameter Control Commands	104
“show” CLI Command	104
“set” CLI Command	104
Configuring Objects that Require Reboot	105
“set” and “show” Command Examples	105
Using Tables & User Strings	107
Working with Tables	107
Using Strings	108
Configuring the AP-600 using CLI commands	108
Log into the AP-600 using HyperTerminal	108
Log into the AP-600 using Telnet	109
Set Basic Configuration Parameters using CLI Commands	109
Set System Name, Location and Contact Information	109
Set Static IP Address for the AP-600	110

Contents

Change Passwords	110
Set Network Names for the Wireless Interface	110
Set WEP Encryption for the Wireless Interface	111
Download an AP-600 Configuration File from your TFTP Server	111
Backup your AP-600 Configuration File	111
Other Network Settings	112
Configure the AP-600 as a DHCP Server	112
Configure the DNS Client	112
Maintain Client Connections using Link Integrity	113
Change your Wireless Interface Settings	113
Set Ethernet Speed and Transmission Mode	114
Set Interface Management Services	114
Configure Syslog	115
Configure Intra BSS	115
Configure MAC Access Control	115
Configure 802.1x Authentication	116
Set RADIUS Parameters	116
CLI Monitoring Parameters	117
Parameter Tables	118
System Parameters	119
Inventory Management Information	119
Network Parameters	119
IP Configuration Parameters	119
DHCP Server Parameters	120
Link Integrity Parameters	121
Interface Parameters	121
Wireless Interface Parameters	121
Ethernet Interface Parameters	124
Management Parameters	124
SNMP Parameters	124
HTTP (web browser) Parameters	124
Telnet Parameters	125
Serial Port Parameters	125
TFTP Server Parameters	125
IP Access Table Parameters	126
Filtering Parameters	126
Ethernet Protocol Filtering Parameters	126
Static MAC Address Filter Table	127
Proxy ARP Parameters	127
IP ARP Filtering Parameters	127
Broadcast Filtering Table	127

Contents



- TCP/UDP Port Filtering 128
- Alarms Parameters 129
 - SNMP Table Host Table Parameters 129
 - Syslog Parameters 129
- Bridge Parameters 130
 - Spanning Tree Parameters 130
 - Storm Threshold Parameters 130
 - Intra BSS Subscriber Blocking 131
 - Packet Forwarding Parameters 131
- Security Parameters 131
 - Wireless Interface Security Parameters 131
 - MAC Access Control Parameter 132
- RADIUS Parameters 132
 - Primary and Backup RADIUS Server Table Parameters 132
- Other Parameters 134
 - IAPP Parameters 134
 - SpectraLink VoIP Parameters (AP-600b Only) 134
- B ASCII Character Chart 135**
- C Specifications 136**
 - Hardware Specifications 136
 - Physical Specifications 136
 - Electrical Specifications 136
 - Environmental Specifications 136
 - Ethernet Interface 136
 - Serial Port Interface 136
 - Active Ethernet Interface 137
 - HTTP Interface 137
 - Radio Specifications 137
 - 802.11a Channel Frequencies for the AP-600a 137
 - FCC (U.S., Canada, Australia) 137
 - ETSI (Europe) 138
 - Japan (MKK) 138
 - Singapore 138
 - 802.11b Channel Frequencies for the AP-600b 139
 - Wireless Communication Range 140
- D Technical Support 141**

Contents



Introduction

In This Chapter

- [Introducing the AP-600](#)
- [The Product Package](#)
- [System Requirements](#)
- [IEEE 802.11 Specifications](#)
- [Wireless Networking Concepts](#)
- [Management and Monitoring Capabilities](#)
- [Active Ethernet](#)
- [Software Features](#)

Introducing the AP-600

The AP-600 is a high performance wireless Access Point that includes an integrated antenna and radio. The AP-600 comes in two models: AP-600a, which complies with the IEEE 802.11a wireless standard, and AP-600b, which complies with the IEEE 802.11b wireless standard (see [IEEE 802.11 Specifications](#) for details). Both models provide mobile clients with wireless access to a network infrastructure.

Proxim is a leading manufacturer of wireless networking equipment. Proxim's unmatched expertise in radio networking technology, combined with the company's extensive experience serving the communication needs of the mobile computing user, have kept Proxim at the forefront of the wireless Local Area Networking (LAN) market.

Document Conventions

- The term, AP-600, is used to describe features that are available with both the AP-600a and the AP-600b.
- The term, **802.11**, is used to describe features that apply to both the 802.11a and 802.11b standards.
- Blue text indicates a link to a topic or Web address. If you are viewing this documentation on your computer, click the blue text to jump to the linked item.



NOTE

A Note indicates important information that helps you make better use of your computer.



CAUTION

A Caution indicates either potential damage to hardware or loss of data and tells you how to avoid the problem.

Introduction

The Product Package

Each AP-600 comes with the following:

- One metal base for ceiling or desktop mounting (includes two screws)
- Mounting hardware
 - Four 3.5 mm x 40 mm screws
 - Four 6 mm x 35 mm plugs
- One power supply
- One ORiNOCO Installation CD-ROM that contains the following:
 - Software Installation Wizard
 - ScanTool
 - Solarwinds TFTP software
 - HTML Help
 - this user's guide in PDF format
- One AP-600 *Quick Start Guide*

If any of these items are missing or damaged, please contact your reseller or ORiNOCO Technical Support (see [Technical Support](#) for contact information).

System Requirements

To begin using an AP-600, you must have the following minimum requirements:

- A 10Base-T Ethernet or 100Base-TX Fast Ethernet switch or hub
- At least one of the following IEEE 802.11-compliant devices:
 - An 802.11a client device if you have an AP-600a
 - An 802.11b client device if you have an AP-600b
- A computer that is connected to the same IP network as the AP-600 and has one of the following Web browsers installed:
 - Microsoft Internet Explorer 5.5 or later (recommended)
 - Netscape 4.x or later(The computer is required to configure the AP-600 using the HTTP interface.)

IEEE 802.11 Specifications

In 1997, the Institute of Electrical and Electronics Engineers (IEEE) adopted the 802.11 standard for wireless devices operating in the 2.4 GHz frequency band. This standard includes provisions for three radio technologies: direct sequence spread spectrum, frequency hopping spread spectrum, and infrared. Devices that comply with the 802.11 standard operate at a data rate of either 1 or 2 Megabits per second (Mbps/sec).

In 1999, the IEEE modified the 802.11 standard to support direct sequence devices that can operate at speeds of up to 11 Mbps/sec. The IEEE ratified this standard as **802.11b**. 802.11b devices are backwards compatible with 2.4 GHz 802.11 direct sequence devices (that operate at 1 or 2 Mbps/sec). The AP-600b complies with the IEEE 802.11b standard.

Also in 1999, the IEEE modified the 802.11 standard to support devices operating in the 5 GHz frequency band. This standard is referred to as **802.11a**. 802.11a devices are not compatible with 2.4 GHz 802.11 or 802.11b devices. 802.11a radios use a radio technology called Orthogonal Frequency Division Multiplexing (OFDM) to achieve data rates of up to 54 Mbps/sec. In addition, Proxim's 802.11a products support an extension of the 802.11a standard, known as **2X™ Turbo** mode. 2X Turbo mode is not part of the 802.11a standard (so devices using this mode from different vendors may not necessarily be interoperable with each other) but it allows data rates of up to 108 Mbps/sec. The AP-600a complies with the IEEE 802.11a standard.

NOTE

With the exception of the radio configuration settings, all of the information in this user guide applies to both models, unless otherwise noted.

Wireless Networking Concepts

The AP-600 extends the capability of an existing Ethernet network to devices on a wireless network. Wireless devices can connect to a single Access Point, or they can move between multiple Access Points located within the same vicinity. As wireless clients move from one coverage cell to another, they maintain network connectivity.

To determine the best location for an Access Point, Proxim recommends conducting a Site Survey before placing the device in its final location. For information about how to conduct a Site Survey, contact your local reseller.

Before an Access Point can be configured for your specific networking requirements, it must first be initialized. See [Installation & Basic Configuration](#) for details.

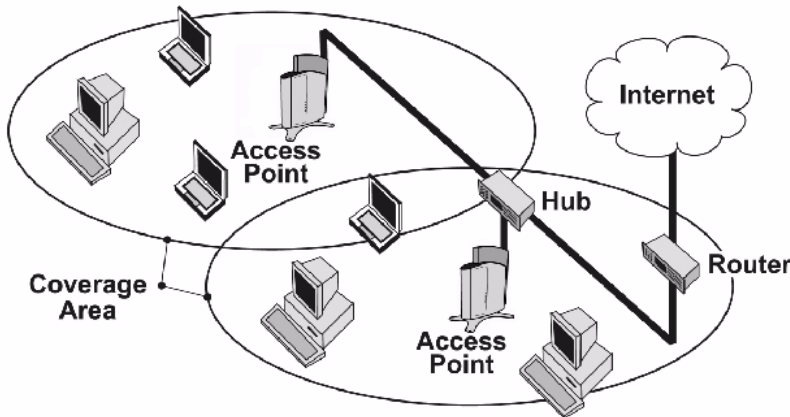

Figure 1-1 Typical wireless network access infrastructure

Once initialized, the network administrator can configure each unit according to the network's requirements. The AP-600 functions as a wireless network access point to data networks. An AP-600 network provides:

- Seamless client roaming
- Easy installation and operation
- Over-the-air encryption of data
- High speed network links

Guidelines for Roaming

- An AP-600 can only communicate with client devices that support its wireless standard. For example, an 802.11a client cannot communicate with an AP-600b and an 802.11b client cannot communicate with an AP-600a. Note that an ORiNOCO 802.11a/b ComboCard can communicate with both the AP-600a and the AP-600b.
- All Access Points must have the same Network Name to support client roaming.
- All workstations with an 802.11 client adapter installed must use either a Network Name of "any" or the same Network Name as the Access Points that they will roam between. If an AP-600b has Closed System enabled, a client must have the same Network Name as the Access Point to communicate (see [Wireless \(AP-600b\)](#)).
- All Access Points and clients must have the same security settings to communicate.
- The Access Points' cells must overlap to ensure that there are no gaps in coverage and to ensure that the roaming client will always have a connection available.
- The coverage area of an AP-600b is larger than the coverage area of an AP-600a. The AP-600b operates in the 2.4 GHz frequency band; the AP-600a operates in the 5 GHz band. Products that operate in the 2.4 GHz band offer greater range than products that operate in the 5 GHz band.
- An AP-600a operates at faster data rates than the AP-600b. 802.11a products like the AP-600a operate at speeds of up to 54 Mb/s (108 Mb/s in Turbo mode); 802.11b products like the AP-600b operate at speeds of up to 11 Mb/s.

Introduction

- All Access Points in the same vicinity should use a unique, independent Channel. By default, the AP-600 automatically scans for available Channels during boot-up but you can also set the Channel manually (see [Interfaces](#) for details).
- Access Points that use the same Channel should be installed as far away from each other as possible to reduce potential interference.

Management and Monitoring Capabilities

There are several management and monitoring interfaces available to the network administrator to configure and manage an AP-600 on the network:

- [HTTP Interface](#)
- [Command Line Interface](#)
- [SNMP Management](#)
- [Wireless Network Manager](#)

HTTP Interface

The HTTP Interface (Web browser Interface) provides easy access to configuration settings and network statistics from any computer on the network. You can access the HTTP Interface over your LAN (switch, hub, etc.), over the Internet, or with a “crossover” Ethernet cable connected directly to your computer’s Ethernet Port.

Command Line Interface

The Command Line Interface (CLI) is a text-based configuration utility that supports a set of keyboard commands and parameters to configure and manage an AP-600.

Users enter Command Statements, composed of CLI Commands and their associated parameters. Statements may be issued from the keyboard for real time control, or from scripts that automate configuration.

For example, when downloading a file, administrators enter the **download** CLI Command along with IP Address, file name, and file type parameters.

You access the CLI over a HyperTerminal serial connection or via Telnet. During initial configuration, you can use the CLI over a serial port connection to configure an Access Point’s IP address. When accessing the CLI via Telnet, you can communicate with the Access Point from over your LAN (switch, hub, etc.), from over the Internet, or with a “crossover” Ethernet cable connected directly to your computer’s Ethernet Port.

See [Command Line Interface \(CLI\)](#) for more information on the CLI and for a list of CLI commands and parameters.

SNMP Management

In addition to the HTTP and the CLI interfaces, you can also manage and configure an AP-600 using the Simple Network Management Protocol (SNMP). Note that this requires an SNMP manager program, like HP Openview or Castlerock’s SNMPC.

The AP-600 supports several Management Information Base (MIB) files that describe the parameters that can be viewed and/or configured over SNMP:

- MIB-II (RFC 1213)
- Bridge MIB (RFC 1493)
- Ethernet-like MIB (RFC 1643)
- 802.11 MIB
- ORiNOCO Enterprise MIB

Proxim provides these MIB files on the CD included with each Access Point. You need to compile one or more of the above MIBs into your SNMP program’s database before you can manage an Access Point using SNMP. Refer to the documentation that came with your SNMP manager for instructions on how to compile MIBs.

Introduction

The Enterprise MIB defines the read and read-write objects that can be viewed or configured using SNMP. These objects correspond to most of the settings and statistics that are available with the other management interfaces. Refer to the Enterprise MIB for more information; the MIB can be opened with any text editor, such as Microsoft Word, Notepad, or WordPad.

NOTE

The remainder of this guide describes how to configure an AP-600 using the HTTP Web interface or the CLI interface. For information on how to manage devices using SNMP, refer to the documentation that came with your SNMP program. Also, refer to the MIB files for information on the parameters available via SNMP.

Wireless Network Manager

The Wireless Network Manager is Proxim's premier management tool for Access Points and Outdoor Routers. It provides a single management interface that lets an IT manager configure, manage, upgrade, and troubleshoot thousands of wireless devices from anywhere in the world. The Wireless Network Manager simplifies network maintenance and easily integrates in an existing SNMP management system.

See Proxim's Web site at <http://www.proxim.com> for more information on the Wireless Network Manager.

Active Ethernet

The AP-600 is equipped with an 802.3af-compliant Active Ethernet module. Active Ethernet (AE) delivers both data and power to the access point over a single Ethernet cable. If you choose to use Active Ethernet, there is no difference in operation; the only difference is in the power source.

- The Active Ethernet (AE) integrated module receives ~48 VDC over a standard Category 5 Ethernet cable.
- To use Active Ethernet, you must have an AE hub (also known as a power injector) connected to the network.
- The cable length between the AE hub and the Access Point should not exceed 100 meters (approximately 325 feet).
- The AE hub is not a repeater and does not amplify the Ethernet data signal.
- If connected to an AE hub and an AC power simultaneously, the Access Point draws power from Active Ethernet.
- Maximum power supplied to an Access Point is 11 Watts; the unit typically draws approximately 10 Watts.

Also see [Electrical Specifications](#).

NOTE

The AP-600's 802.3af-compliant Active Ethernet module is backwards compatible with all ORiNOCO Active Ethernet hubs that do not support the IEEE 802.3af standard.

Software Features

The table below compares the software features available for the AP-600a and the AP-600b:

Feature	AP-600a 802.11a	AP-600b 802.11b	Comments
Number of stations per Basic Service Set (BSS)	up to 50	up to 250	
HTTP Server	Yes	Yes	
Telnet / CLI	Yes	Yes	
SNMP Agent	Yes	Yes	
Emergency Reset to Default Configuration	Yes	Yes	
DHCP Client	Yes	Yes	
DHCP Server	Yes	Yes	
TFTP	Yes	Yes	
RADIUS Access Control	Yes	Yes	
Fallback to Primary RADIUS Server	Yes	Yes	
RADIUS Session Timeout	Yes	Yes	

Introduction

Feature	AP-600a 802.11a	AP-600b 802.11b	Comments
RADIUS Multiple MAC Address Formats	Yes	Yes	
RADIUS DNS Host Name Support	Yes	Yes	
RADIUS Start/Stop Accounting	Yes	Yes	
802.1x	Yes	Yes	
802.1d bridging	Yes	Yes	
MAC Access Control Table	Yes	Yes	
Protocol Filtering	Yes	Yes	
Multicast/Broadcast Storm Filtering	Yes	Yes	
Proxy ARP	Yes	Yes	
ICMP Echo Response	Yes	Yes	
Hardware Watchdog Timer	Yes	Yes	
Roaming	Yes	Yes	
Link Integrity	Yes	Yes	
Automatic Channel Select	Yes	Yes	
WEP	Yes	Yes	Key lengths supported by AP-600b: 64-bit and 128-bit Key lengths supported by AP-600a: 64-bit, 128-bit, and 152-bit
WEP Plus (Weak Key Avoidance)	No	Yes	Available only one way (AP to client) if using an ORiNOCO 802.11a/b ComboCard or a non-ORiNOCO client.
WDS Relay	No	Yes	
Remote Link Test	No	Yes	
Link Test Responder	No	Yes*	
Medium Density Distribution	No	Yes*	
Distance between APs	No	Yes*	
Ultra High Density	No	Yes*	
Closed System	No	Yes	
Interference Robustness	No	Yes	
Load Balancing	No	Yes*	
SpectraLink VoIP Support	No	Yes	
Fragmentation	Yes	Yes	For AP-600b, Fragmentation is implemented as part of the Interference Robustness feature.
Blocking Intra BSS Clients	Yes	Yes	
Packet Forwarding	Yes	Yes	
TCP/UDP Port Filtering	Yes	Yes	
Dynamic Frequency Selection (DFS)	Yes	No	DFS is required for 802.11a products sold in Europe
Per User Per Session Encryption	Yes	No	Use in conjunction with 802.1x
Syslog Messaging	Yes	Yes	
2X Turbo Mode	Yes	No	Not available in all countries

*This feature is not available if you are using an ORiNOCO 802.11a/b ComboCard or a non-ORiNOCO client with the AP-600b.

Introduction

The following table provides detailed information on the some of the differences between the 802.11a and 802.11b feature sets.

	AP-600a (802.11a)	AP-600b (802.11b)
Physical Layer Type (Modulation Type)	OFDM (Orthogonal Frequency Division Multiplexing)	DSSS (Direct Sequence Spread Spectrum)
Auto Channel Select	Enable (default) Disable Note: A user cannot manually select a channel for products sold in Europe; these products require automatic channel selection using DFS. See Dynamic Frequency Selection (DFS) .	Enable (default) Disable
Frequency Channel	Available Channels vary by regulatory domain and/or country. See 802.11a Channel Frequencies for the AP-600a for details.	Available Channels vary by regulatory domain and/or country. See 802.11b Channel Frequencies for the AP-600b for details.
Transmit Rate	0 - Auto Fallback (default) 6 Mbits/sec 9 Mbits/sec 12 Mbits/sec 18 Mbits/sec 24 Mbits/sec 36 Mbits/sec 48 Mbits/sec 54 Mbits/sec For 2X Turbo mode (not available in all countries): 0 - Auto Fallback (default) 12 Mbits/sec 18 Mbits/sec 24 Mbits/sec 36 Mbits/sec 48 Mbits/sec 72 Mbits/sec 96 Mbits/sec 108 Mbits/sec	N/A
Distance Between APs	N/A	Large (default) Medium Small Minicell Microcell
Multicast Rate	N/A	1 Mbits/sec 2 Mbits/sec 5.5 Mbits/sec 11 Mbits/sec Available options depend on Distance Between APs setting
Interference Robustness	N/A	Enable (default) Disable
Closed System	N/A	Enable Disable (default)
Load Balancing	N/A	Enable (default) Disable
Medium Density Distribution	N/A	Enable (default) Disable

2

Installation & Basic Configuration

In This Chapter

This chapter describes how to install and configure an AP-600 for the first time.

- [Prerequisites](#)
- [Installation](#)
- [Initialization](#)
- [Download the Latest Software](#)
- [Additional Hardware Features](#)

Prerequisites

Before installing an AP-600, you need to gather certain network information. The following section identifies the information you need.

Network Name (SSID of the wireless cards)	You must assign the Access Point a Network Name before wireless users can communicate with it. The clients also need the same Network Name. This is not the same as the System Name, which applies only to the Access Point. The network administrator typically provides the Network Name.
AP-600's IP Address	If you do not have a DHCP server on your network, then you need to assign the Access Point an IP address that is valid on your network.
HTTP Password	Each Access Point requires a read/write password to access the web interface. The default password is "public".
CLI Password	Each Access Point requires a read/write password to access the CLI interface. The default password is "public".
SNMP Read Password	Each Access Point requires a password to allow get requests from an SNMP manager. The default password is "public".
SNMP Read-Write Password	Each Access Point requires a password to allow get and set requests from an SNMP manager. The default password is "public".
Security Settings	You need to determine what security features you will enable on the Access Point.
Authentication Method	A primary authentication server may be configured; a backup authentication server is optional. The network administrator typically provides this information.
Authentication Server Shared Secret	This is a password shared between the Access Point and the RADIUS authentication server (so both passwords must be the same), and is typically provided by the network administrator.
Authentication Server Authentication Port	This is a port number (default is 1812) and is typically provided by the network administrator.
Client IP Address Pool Allocation Scheme	The Access Point can automatically provide IP addresses to clients as they sign on. The network administrator typically provides the IP Pool range.
DNS Server IP Address	The network administrator typically provides this IP Address.

Installation & Basic Configuration

Installation

Follow these steps to install an AP-600:

1. Unpack the Access Point and accessories from the shipping box.
2. If you intend to install the unit free-standing or if you intend to mount it to the ceiling, use a Phillips screwdriver to attach the metal base to the underside of the unit. The metal base and screws are provided. See [Mounting Options](#) for additional information.

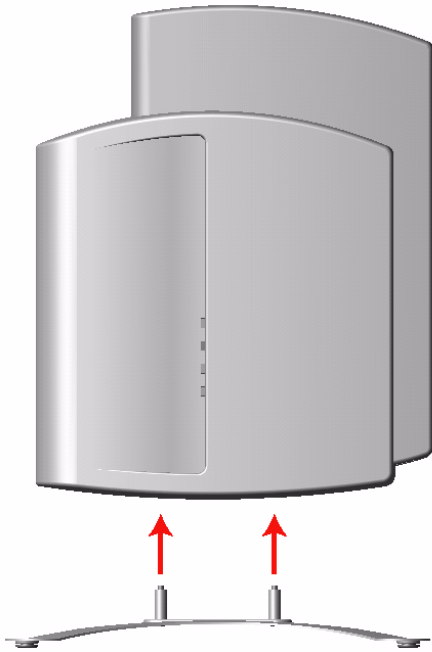

Figure 2-1 Attach the Metal Base

3. Press down on the cable-cover lock located in the front-center of the unit to release the cable cover.

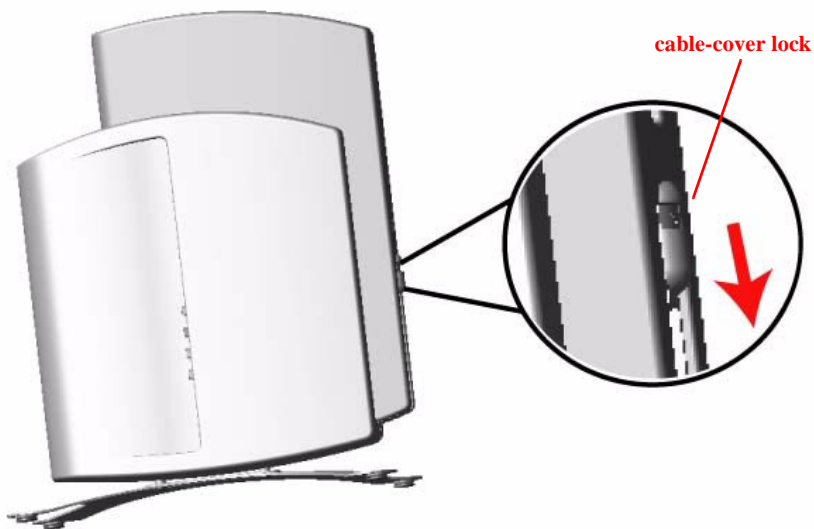

Figure 2-2 Unlock the Cable Cover

4. Remove the cable cover from the unit.

Installation & Basic Configuration

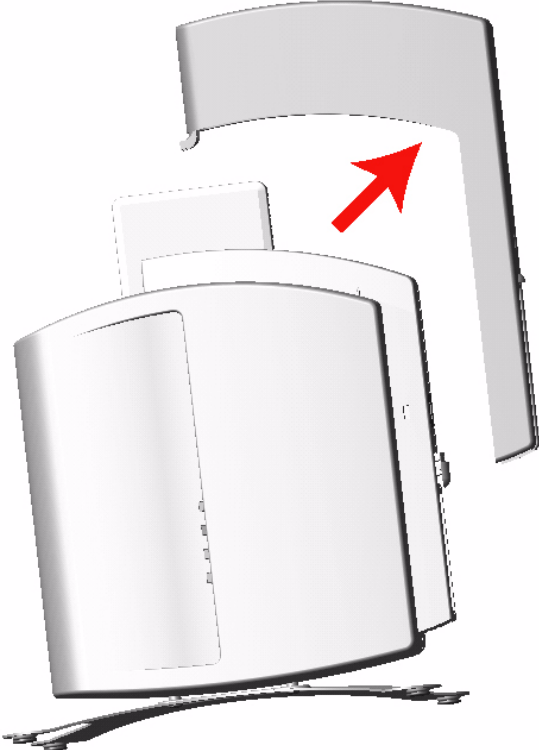

Figure 2-3 Remove Cable Cover

5. Remove the front cover (the side with the LED indicators) from the unit.

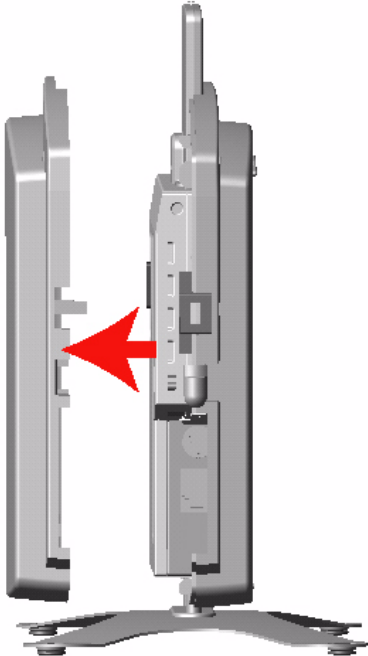

Figure 2-4 Remove the Front Cover

6. Remove the back cover from the unit.

Installation & Basic Configuration

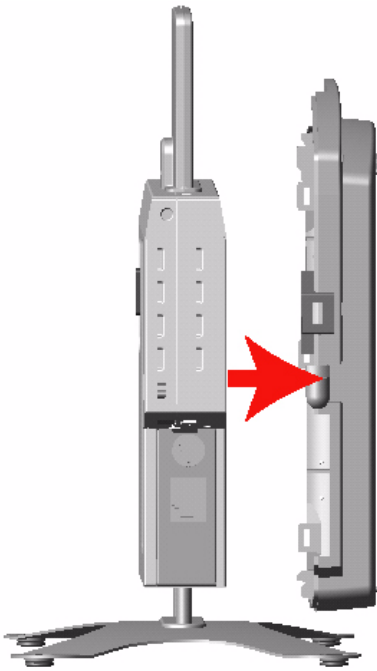

Figure 2-5 Remove the Back Cover

7. Connect one end of an Ethernet cable to the Access Point's Ethernet port. The other end of the cable should not be connected to another device until after the installation is complete.
 - Use a straight-through Ethernet cable if you intend to connect the Access Point to a hub, switch, patch panel, or Active Ethernet power injector.
 - Use a cross-over Ethernet cable if you intend to connect the Access Point to a single computer.
8. If you are not using Active Ethernet (or you want to connect the Access Point to Active Ethernet and AC power simultaneously), attach the AC power cable to the Access Point's power port.

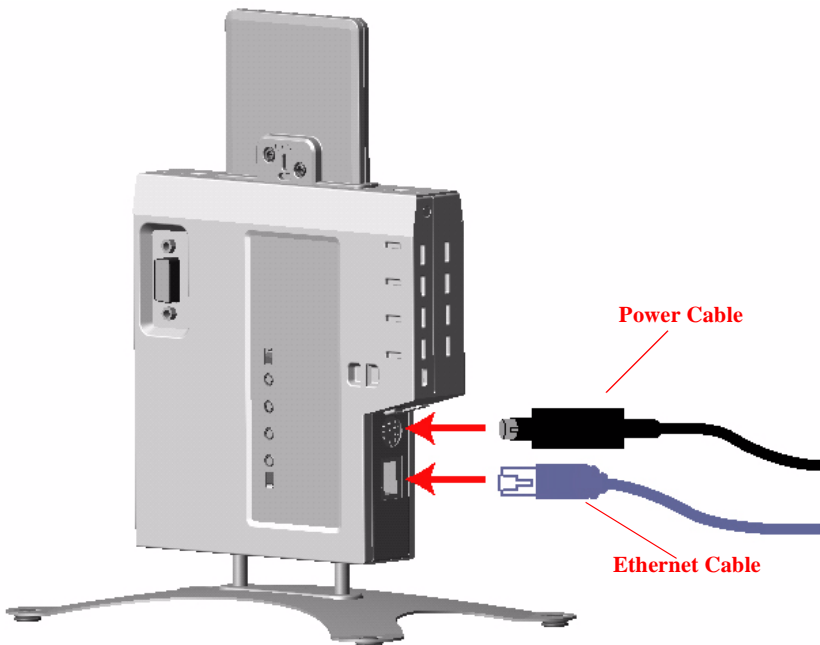

Figure 2-6 Attach Ethernet Cable and Power Cable

Installation & Basic Configuration

⇒ NOTE

Once attached, the power cable locks into place. To disconnect the power cable, slide back the black plastic fitting and gently pull the cable from the connector.

9. Connect the free end of the Ethernet cable to a hub, switch, patch panel, Active Ethernet power injector, or an Ethernet port on a computer.
10. If using AC power, connect the power cord to a power source (such as a wall outlet) to turn on the unit.
11. Configure and test the unit. See [Initialization](#) for details.
12. Download the latest software to the unit, if necessary. See [Download the Latest Software](#) for details.
13. Place the unit in the final installation location. See [Mounting Options](#) for mounting options and instructions.

⇒ NOTE

Proxim recommends that you perform a Site Survey prior to determine the installation location for your AP-600 units. For information about how to conduct a Site Survey, contact your local reseller.

14. Replace the back cover, front cover, and cable cover. Be careful to avoid trapping the power and Ethernet cables when replacing the cable cover.



Figure 2-7 Assembled Unit

15. If desired, you can attach a Kensington lock to secure the cable cover into place. This will protect the unit from unauthorized tampering. See [Kensington Security Slot](#) for details.

Initialization

Proxim provides two tools to simplify the initialization and configuration of an AP-600:

- [ScanTool](#)
- [Setup Wizard](#)

ScanTool is included on the ORiNOCO CD; the Setup Wizard launches automatically the first time you access the HTTP interface.

NOTE

These initialization instructions describe how to configure an AP-600 over an Ethernet connection using ScanTool and the HTTP interface. If you want to configure the unit over the serial port, see [Setting IP Address using Serial Port and Normal CLI](#) for information on how to access the CLI over a serial connection and [Command Line Interface \(CLI\)](#) for a list of supported commands.

ScanTool

ScanTool is a software utility that is included on the installation CD-ROM. The tool automatically detects the Access Points installed on your network, regardless of IP address, and lets you configure each unit's IP settings. In addition, you can use ScanTool to download new software to an AP-600 that does not have a valid software image installed (see [Client Connection Problems](#)).

To access the HTTP interface and configure the AP-600, the AP-600 must be assigned an IP address that is valid on its Ethernet network. By default, the AP-600 is configured to obtain an IP address automatically from a network Dynamic Host Configuration Protocol (DHCP) server during boot-up. If your network contains a DHCP server, you can run ScanTool to find out what IP address the AP-600 has been assigned. If your network does not contain a DHCP server, the Access Point's IP address defaults to 169.254.128.132. In this case, you can use ScanTool to assign the AP-600 a static IP address that is valid on your network.

ScanTool Instructions

Follow these steps to install ScanTool, initialize the Access Point, and perform initial configuration:

1. Locate the unit's Ethernet MAC address and write it down for future reference. The MAC address is printed on the product label. Each unit has a unique MAC address, which is assigned at the factory.
2. Confirm that the AP-600 is connected to the same LAN subnet as the computer that you will use to configure the AP-600.
3. Power up, reboot, or reset the AP-600.
 - Result: The unit requests an IP Address from the network DHCP server.
4. Insert the ORiNOCO CD into the CD-ROM drive of the computer that you will use to configure the AP-600.
 - Result: The installation program will launch automatically.
5. Follow the on-screen instructions to install the Access Point software and documentation.

NOTE

The ORiNOCO Installation program supports the following operating systems:

- Windows 98
- Windows 2000
- Windows ME
- Windows XP

Installation & Basic Configuration

6. After the software has been installed, double-click the **ScanTool** icon on the Windows desktop to launch the program (if the program is not already running).
 - Result: ScanTool scans the subnet and displays all detected ORiNOCO Access Points. The ScanTool's **Scan List** screen appears, as shown in the following example.

⇒ NOTE

If your computer has more than one network adapter installed, you will be prompted to select the adapter that you want ScanTool to use before the **Scan List** appears. If prompted, select an adapter and click **OK**. You can change your adapter setting at any time by clicking the **Select Adapter** button on the **Scan List** screen. Note that the **ScanTool Network Adapter Selection** screen will not appear if your computer only has one network adapter installed.

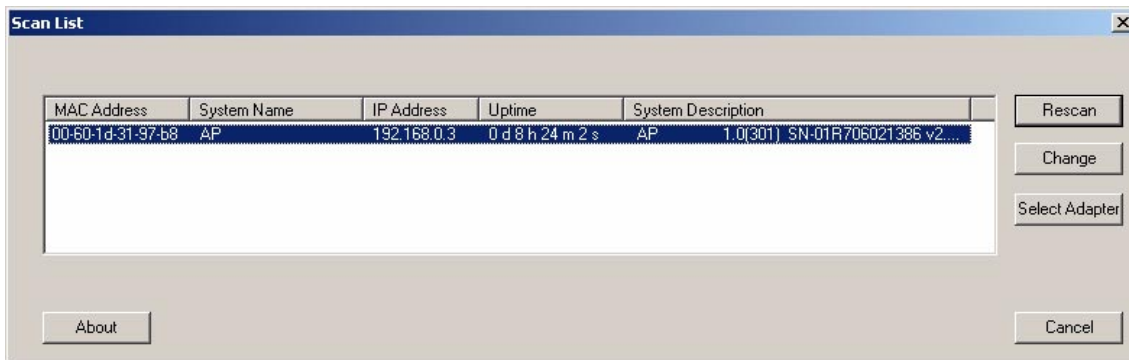

Figure 2-8 Scan List

7. Locate the MAC address of the AP-600 you want to initialize within the Scan List.

⇒ NOTE

If your Access Point does not show up in the Scan List, click the **Rescan** button to update the display. If the unit still does not appear in the list, see [Troubleshooting](#) for suggestions. Note that after rebooting an Access Point, it may take up to five minutes for the unit to appear in the Scan List.

8. Do one of the following:
 - If the AP-600 has been assigned an IP address by a DHCP server on the network, write down the IP address and click **Cancel** to close ScanTool. Proceed to [Setup Wizard](#) for information on how to access the HTTP interface using this IP address.
 - If the AP-600 has not been assigned an IP address (in other words, the unit is using its default IP address, 169.254.128.132), follow these steps to assign it a static IP address that is valid on your network:
 1. Highlight the entry for the AP-600 you want to configure.
 2. Click the **Change** button.
 - Result: the **Change** screen appears.

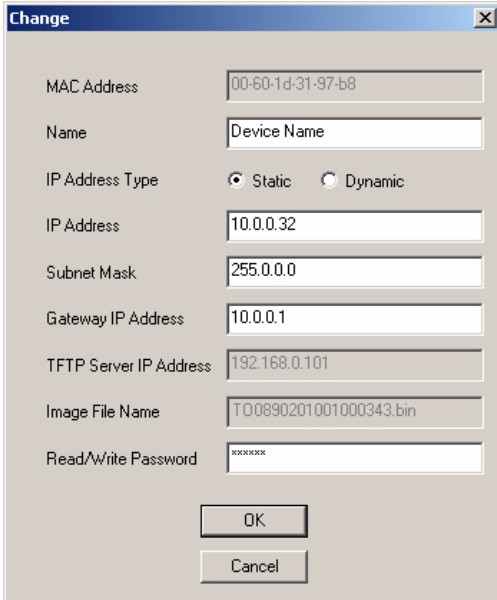

Figure 2-9 Scan Tool Change Screen

3. Set **IP Address Type** to **Static**.
4. Enter a static **IP Address** for the AP-600 in the field provided. You must assign the unit a unique address that is valid on your IP subnet. Contact your network administrator if you need assistance selecting an IP address for the unit.
5. Enter your network's **Subnet Mask** in the field provided.
6. Enter your network's **Gateway IP Address** in the field provided.
7. Enter the SNMP Read/Write password in the **Read/Write Password** field (for new units, the default SNMP Read/Write password is "public").

NOTE

The TFTP Server IP Address and Image File Name fields are only available if ScanTool detects that the AP-600 does not have a valid software image installed. See [Client Connection Problems](#).

8. Click **OK** to save your changes.
 - Result: The Access Point will reboot automatically and any changes you made will take effect.
9. When prompted, click **OK** a second time to return to the **Scan List** screen.
10. Click **Cancel** to close the ScanTool.
11. Proceed to [Setup Wizard](#) for information on how to access the HTTP interface.

Installation & Basic Configuration

Setup Wizard

The first time you connect to an AP-600's HTTP interface, the Setup Wizard launches automatically. The Setup Wizard provides step-by-step instructions for how to configure the Access Point's basic operating parameter, such as Network Name, IP parameters, system parameters, and management passwords.

Setup Wizard Instructions

Follow these steps to access the Access Point's HTTP interface and launch the Setup Wizard:

1. Open a Web browser on a network computer.

⇒ NOTE

The HTTP interface supports the following Web browser:

- Microsoft Internet Explorer 5.5 or later
- Netscape 4.x or later

2. If necessary, disable the browser's Internet proxy settings. For Internet Explorer users, follow these steps:
 - Select **Tools > Internet Options...**
 - Click the **Connections** tab.
 - Click **LAN Settings...**
 - If necessary, remove the check mark from the **Use a proxy server** box.
 - Click **OK** twice to save your changes and return to Internet Explorer.
3. Enter the Access Point's IP address in the browser's **Address** field and press **Enter**.
 - This is either the dynamic IP address assigned by a network DHCP server or the static IP address you manually configured. See [ScanTool](#) for information on how to determine the unit's IP address and manually configure a new IP address, if necessary.
 - Result: The **Enter Network Password** screen appears.
4. Enter the HTTP password in the **Password** field. Leave the **User Name** field blank. For new units, the default HTTP password is "public".
 - Result: The Setup Wizard will launch automatically.



Figure 2-10 Enter Network Password

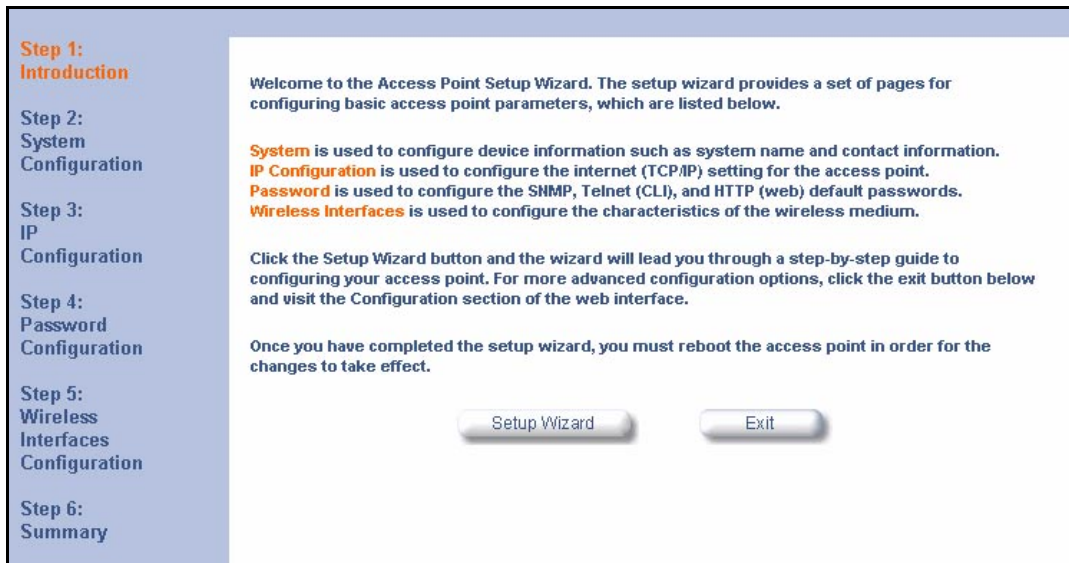

Figure 2-11 Setup Wizard

5. Click **Setup Wizard** to begin. If you want to configure the AP-600 without using the Setup Wizard, click **Exit** and see [Advanced Configuration](#).

The Setup Wizard supports the following navigation options:

- **Save & Next Button:** Each Setup Wizard screen has a **Save & Next** button. Click this button to submit any changes you made to the unit's parameters and continue to the next page. The instructions below describe how to navigate the Setup Wizard using the **Save & Next** buttons.
- **Navigation Panel:** The Setup Wizard provides a navigation panel on the left-hand side of the screen. Click the link that corresponds to the parameters you want to configure to be taken to that particular configuration screen. Note that clicking a link in the navigation panel will not submit any changes you made to the unit's configuration on the current page.
- **Exit:** The navigation panel also includes an **Exit** option. Click this link to close the Setup Wizard at any time.



CAUTION

If you exit from the Setup Wizard, any changes you submitted (by clicking the **Save & Next** button) up to that point will be saved to the unit but will not take effect until it is rebooted.

6. Configure the System Configuration settings and click **Save & Next**. See [System](#) for more information.
7. Configure the Access Point's Basic IP address settings, if necessary, and click **Save & Next**. See [Basic IP Parameters](#) for more information.
8. Assign the AP-600 new passwords to prevent unauthorized access and click **Save & Next**. Each management interface has its own password:
 - SNMP Read Password
 - SNMP Read-Write Password
 - CLI Password
 - HTTP (Web) Password

By default, each of these passwords is set to "public". See [Passwords](#) for more information.

9. Configure the basic wireless interface settings and click **Save & Next**.
 - The following options are available for the AP-600a:
 - **Network Name (SSID):** Enter a Network Name (between 2 and 31 characters long) for the wireless network. You must configure each wireless client to use this name as well.
 - **Auto Channel Select:** By default, the AP-600a scans the area for other Access Points and selects a free or relatively unused communication channel. This helps prevent interference problems and increases network performance. Remove the check mark to disable this option. Note that you cannot disable Auto Channel Select for 802.11a products in Europe (see [Dynamic Frequency Selection \(DFS\)](#) for details).

Installation & Basic Configuration

- **Frequency Channel:** When Auto Channel Select is enabled, this field is read-only and displays the Access Point's current operating channel. When Auto Channel Select is disabled, you can specify the Access Point's channel. If you decide to manually set the unit's channel, ensure that nearby devices do not use the same frequency. Available Channels vary based on regulatory domain. See [802.11a Channel Frequencies for the AP-600a](#). Note that you cannot manually set the channel for 802.11a products in Europe (see [Dynamic Frequency Selection \(DFS\)](#) for details).
- **Transmit Rate:** Use the drop-down menu to select a specific transmit rate for the AP-600a. Choose between 6, 9, 12, 18, 24, 36, 48, 54 Mb/s, and Auto Fallback. The Auto Fallback feature allows the AP-600a unit to select the best transmit rate based on the cell size.
- **WEP Encryption:** Place a check mark in the box provided to enable WEP encryption. See [WEP Encryption](#) for more information.
- **Set Encryption Key 1:** If you enabled Encryption, configure an Encryption Key. This key is used to encrypt and decrypt data between the AP-600a and its wireless clients. Enter the number of characters that correspond to the desired key size, as described below:
 - Enter 10 hexadecimal characters (0-9 and A-F) or 5 ASCII characters (see [ASCII Character Chart](#)) to use 64-bit encryption.
 - Enter 26 hexadecimal characters or 13 ASCII characters to use 128-bit encryption.
 - Enter 32 hexadecimal characters or 16 ASCII characters to use 152-bit encryption.
- The following options are available for the AP-600b:
 - **Network Name (SSID):** Enter a Network Name (between 2 and 31 characters long) for the wireless network. You must configure each wireless client to use this name as well.
 - **Auto Channel Select:** The AP-600b scans the area for other Access Points and selects a free or relatively unused communication channel. This helps prevent interference problems and increases network performance. Remove the check mark to disable this option. If you are setting up a Wireless Distribution System (WDS), it must be disabled. See [Wireless Distribution System \(WDS\)](#) for more information.
 - **Frequency Channel:** When Auto Channel Select is enabled, this field is read-only and displays the Access Point's current operating channel. When Auto Channel Select is disabled, you can specify the Access Point's operating channel. If you decide to manually set the unit's channel, ensure that nearby devices do not use the same frequency (unless you are setting up a WDS). Available Channels vary based on regulatory domain. See [802.11b Channel Frequencies for the AP-600b](#).
 - **Distance Between APs:** Set to **Large**, **Medium**, **Small**, **Microcell**, or **Minicell** depending on the site survey for your system. The distance value is related to the **Multicast Rate** (described next). In general, a larger distance between APs means that your clients operate at slower data rates (on average). See [Distance Between APs](#) for more information.
 - **Multicast Rate:** Sets the rate at which Multicast messages are sent. This value is related to the **Distance Between APs** parameter (described previously). The table below displays the possible Multicast Rates based on the Distance between APs. See [Multicast Rate](#) for more information.

Distance between APs	Multicast Rate
Large	1 and 2 Mb/s
Medium	1, 2, and 5.5 Mb/s
Small	1, 2, 5.5 and 11 Mb/s
Minicell	1, 2, 5.5 and 11 Mb/s
Microcell	1, 2, 5.5 and 11 Mb/s

- **WEP Encryption:** Place a check mark in the box provided to enable WEP encryption. See [WEP Encryption](#) for more information.

Installation & Basic Configuration

- **Set Encryption Key 1:** If you enabled Encryption, configure an Encryption Key. This key is used to encrypt and decrypt data between the AP-600a and its wireless clients. Enter the number of characters that correspond to the desired key size, as described below:
 - Enter 10 hexadecimal characters (0-9 and A-F) or 5 ASCII characters (see [ASCII Character Chart](#)) to use 64-bit encryption.
 - Enter 26 hexadecimal characters (0-9 and A-F) or 13 ASCII characters to use 128-bit encryption.

⇒ NOTE

Additional advanced settings are available in the **Wireless Interface Configuration** screen. See [Wireless \(AP-600a\)](#) or [Wireless \(AP-600b\)](#) for details. See [Security](#) for more information on security features.

10. Review the configuration summary. If you want to make any additional changes, use the navigation panel on the left-hand side of the screen to return to an earlier screen. After making a change, click **Save & Next** to save the change and proceed to the next screen.
11. When finished, click **Reboot** on the Summary screen to restart the AP-600 and apply your changes.

Download the Latest Software

Proxim periodically releases updated software for the AP-600 on its Web site at <http://www.proxim.com>. Proxim recommends that you check the Web site for the latest updates after you have installed and initialized the unit.

Three types of files can be downloaded to the AP-600 from a TFTP server:

- Img (AP software image or kernel)
- Config (configuration file)
- bspBI (BSP/Bootloader firmware file)

Setup your TFTP Server

A Trivial File Transfer Protocol (TFTP) server allows you to transfer files across a network. You can upload files from the AP-600 for backup or copying, and you can download the files for configuration and AP Image upgrades. The Solarwinds TFTP server software is located on the ORiNOCO AP-600 Installation CD-ROM. You can also download the latest TFTP software from Solarwind's Web site at <http://www.solarwinds.net>.

If a TFTP server is not configured and running, you will not be able to download and upload images and configuration files to/from the AP-600. Remember that the TFTP server does not have to be local as long as you have a valid TFTP IP address. Also, a TFTP server does not have to be running for the AP-600 to perform tasks that do not involve file transfers.

After the TFTP server is installed:

- Check to see that TFTP is configured to point to the directory containing the AP Image.
- Make sure you have the proper TFTP server IP address, the proper AP Image file name, and that the TFTP server is operational.
- **Make sure the TFTP server is configured to both Transmit and Receive files, with no automatic shutdown or time-out.**

Download Updates from your TFTP Server using the Web Interface

1. Download the latest software from <http://www.proxim.com>.
2. Copy the latest software updates to your TFTP server.
3. In the Web Interface, click the **Commands** button and select the **Download** tab.
4. Enter the IP address of your TFTP server in the field provided.
5. Enter the **File Name** (including the file extension). Enter the full directory path and file name. If the file is located in the default TFTP directory, you need enter only the file name.
6. Select the **File Type** from the drop-down menu (use *Img* for software updates).
7. Select **Download & Reboot** from the **File Operation** drop-down menu.
8. Click **OK**.
9. The Access Point will reboot automatically when the download is complete.

Installation & Basic Configuration

Download Updates from your TFTP Server using the CLI Interface

1. Download the latest software from <http://www.proxim.com>.
2. Copy the latest software updates to your TFTP server.
3. Open the CLI interface via Telnet or a serial connection.
4. Enter the CLI password when prompted.
5. Type **set tftpfilename <file name>** (include the file extension) and press **Enter**.
6. Type **set tftpfiletype img** and press **Enter**.
7. Type **set tftpipaddr <IP address of your TFTP server>** and press **Enter**.
8. Type **show tftp** and confirm that the file name, file type, and IP address are correct.
9. Type **download *** and press **Enter**.
 - Result: The download will begin. Be patient while the image is downloaded to the Access Point.
10. When the download is complete, type **reboot 0** and press **Enter**.

NOTE

See [Command Line Interface \(CLI\)](#) for more information.

Additional Hardware Features

- [Mounting Options](#)
- [Kensington Security Slot](#)
- [LED Indicators](#)

Mounting Options

There are three mounting options for the AP-600, described below. If you intend to install the unit in a plenum, see [Installing the AP-600 in a Plenum](#).

Desktop Mount

This is the standard installation for the AP-600. See [Installation](#) for instructions.

Wall Mount

Follow these steps to mount the AP-600 on a wall:

1. Identify the location where you intend to mount the unit.

NOTE

For best results, mount the unit vertically. In other words, the antenna should be pointing up or down but not sideways.

2. Unplug the Access Point's power supply, if necessary.
3. Use a Phillips screwdriver to remove the metal base from the underside of the AP-600, if necessary.
4. Press down on the cable cover lock to release the cable cover. See [Unlock the Cable Cover](#) for an illustration.
5. Remove the cable cover from the unit. See [Remove Cable Cover](#) for an illustration.
6. Remove the front cover from the unit. See [Remove the Front Cover](#) for an illustration.
7. Remove the back cover from the unit. See [Remove the Back Cover](#) for an illustration.
8. Place the back cover on the mounting location and mark the center of the three mounting holes.
9. Remove the cover from the wall and drill a hole at each of the locations you marked above. Each hole should be wide enough to hold a mounting plug (which is 6 mm x 35 mm).
10. Insert a plug into each hole. The AP-600 comes with four 6 mm x 35 mm plugs; you only need to use three of these when wall mounting the unit.
11. Insert a screw into each of the mounting holes molded into the back cover. The AP-600 comes with four 3.5 mm x 40 mm pan-head screws; you only need to use three of these when wall mounting the unit.

Installation & Basic Configuration

12. Insert the screws into the wall plugs. Use a screwdriver to tighten the screws and attach the back cover to the wall. In the following example, the back cover is mounted upside down (the two holes are at the bottom).

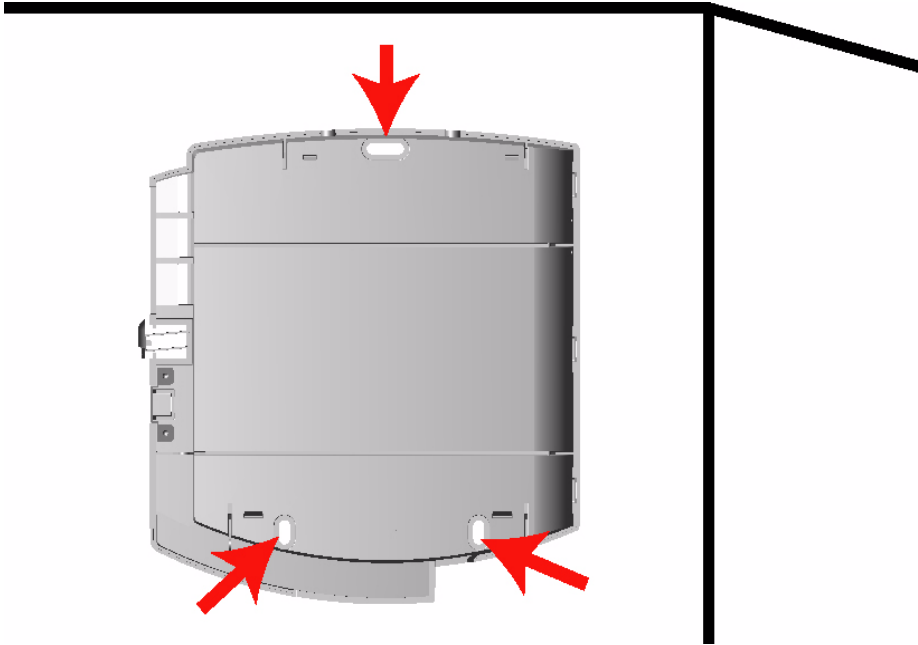

Figure 2-12 Attach the Back Cover to the Wall

13. Attach Ethernet and power cables to the AP-600 unit, if necessary.
14. Snap the unit into the back cover. In the following example, the unit is mounted upside down and its antenna is facing down.

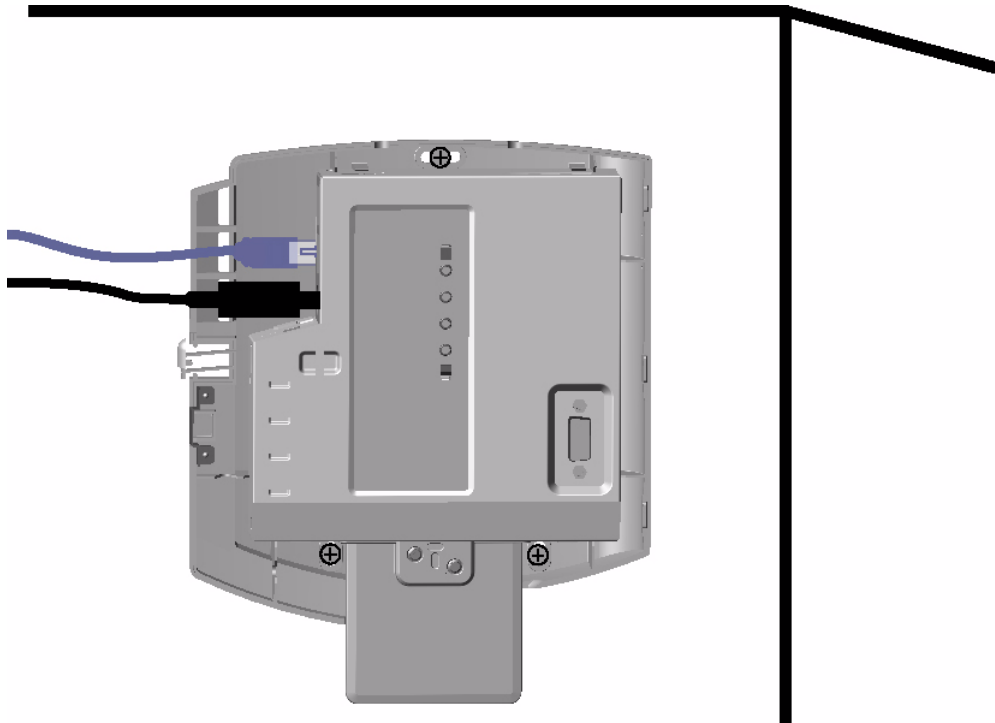

Figure 2-13 AP-600 Mounted on a Wall

Installation & Basic Configuration

15. Replace the front cover.
16. Replace the cable cover.
17. Turn on the AP-600.

Ceiling Mount

Follow these steps to mount the AP-600 to a ceiling:

1. Unplug the Access Point's power supply, if necessary.
2. Use a Phillips screwdriver to attach the metal base to the underside of the AP-600, if necessary. See [Attach the Metal Base](#) for an illustration.
3. Feed a mounting screw through each of the four rubber feet. The AP-600 comes with four 3.5 mm x 40 mm pan-head screws.
4. Remove the screws from the rubber feet.
5. Turn the AP-600 upside down position the base against the ceiling where you want to mount the unit.
6. Mark the center of the four mounting holes in the rubber feet.
7. Set the AP-600 aside and drill a hole at each of the locations you marked above. Each hole should be wide enough to hold a mounting plug (which is 6 mm x 35 mm).
8. Insert a plug into each hole. The AP-600 comes with four 6 mm x 35 mm plugs.
9. Insert the screws into the holes you made previously in the rubber feet.
10. Insert the screws into the wall plugs. Use a screwdriver to tighten the screws and attach the Access Point's metal base to the ceiling.

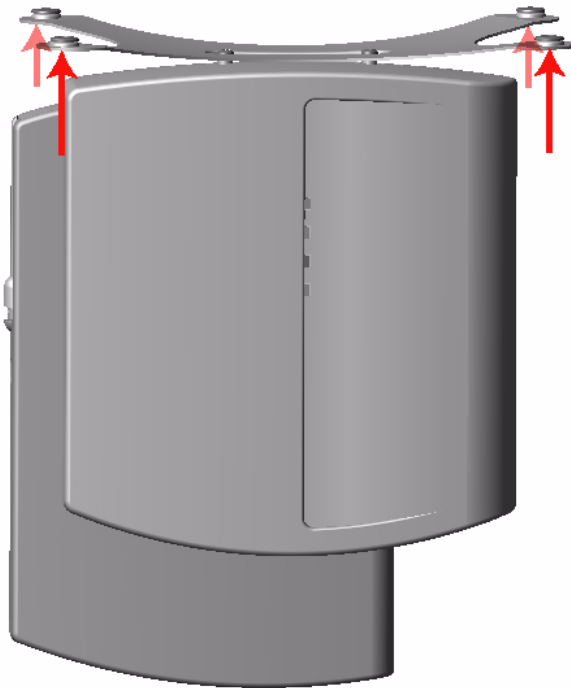

Figure 2-14 Mounting the AP-600 to the Ceiling

Installation & Basic Configuration

Installing the AP-600 in a Plenum

In an office building, plenum is the space between the structural ceiling and the tile ceiling that is provided to help air circulate. Many companies also use the plenum to house communication equipment and cables. However, these products and cables must comply with certain safety requirements, such as Underwriter Labs (UL) Standard 2043: "Standard for Fire Test for Heat and Visible Smoke Release for Discrete Products and Their Accessories Installed in Air-Handling Spaces".

The AP-600 has been certified under UL Standard 2043 and can be installed in the plenum only when the following conditions apply:

- The unit uses Active Ethernet (AE) to receive power over a plenum-rated Category 5 Ethernet cable (the power cable must not be connected to the unit).
- The unit's plastic covers have been removed (this includes the cable cover, the front cover, and the back cover).

Kensington Security Slot

The AP-600 enclosure includes a Kensington Security Slot for use with a Kensington locking mechanism. When properly installed, a Kensington lock can prevent unauthorized personnel from stealing the AP-600. In addition, the Kensington locks secures the cable cover in place, which prevents tampering with the Ethernet and power cables.

The Kensington Security Slot is shown in the illustrations below (the figure on the left shows the slot with the cable cover attached; the figure on the right shows the slot with the cable cover removed). See <http://www.kensington.com> for information on Kensington security solutions.

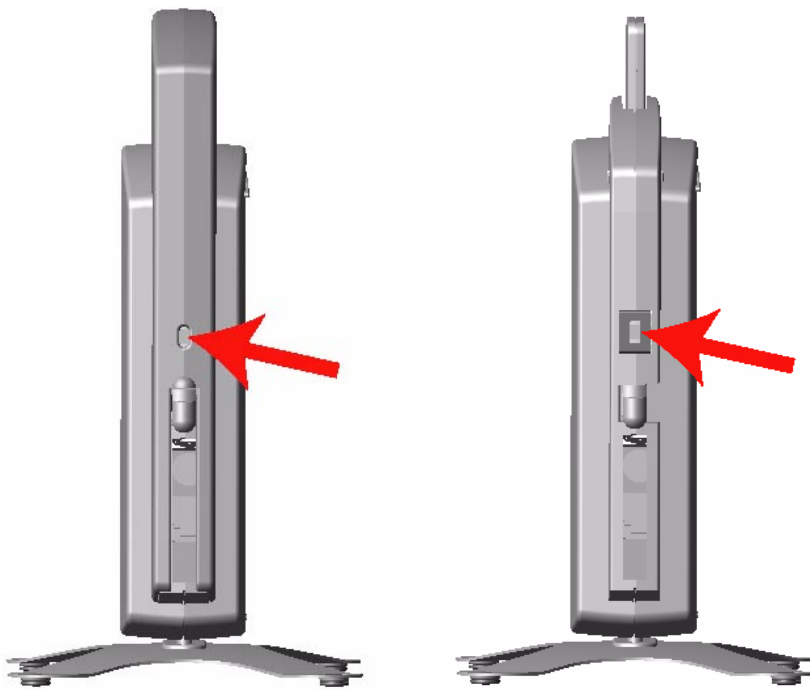

Figure 2-15 Kensington Security Slot

Installation & Basic Configuration

LED Indicators

The AP-600 has four LED indicators. The LEDs are identified in [LED Indicators Illustrated](#) and exhibit the following behavior:

Power	Ethernet Link	Ethernet Activity	Wireless Activity	Indication
Solid Green	Green when link exists	Green flash with data activity	Green flash with data activity	Normal Operation
Solid Amber	Solid Amber	Solid Amber	Solid Amber	Rebooting
Solid Green	Solid Amber	Solid Amber	Solid Amber	Reset to Factory Defaults command issued
Solid Red	Off	Off	Off	SDRAM Test Failure
Blinking Red	Blinking Red or Off	Blinking Red	Off	Hardware Timer Test Failure
Blinking Red	Off	Off	Blinking Red	Flash Test Failure
Solid Red	Blinking Red or Off	Solid Red	Off	Ethernet Test Failure
Solid Red	Off	Off	Solid Red	Wireless Test Failure
Blinking Amber	Blinking Amber or Off	Blinking Amber or Off	Off	Missing or bad AP image
Solid Amber	Solid Amber	Solid Amber	Solid Amber	Missing or bad bootloader image (all LEDs remain solid amber)
n/a	n/a	n/a	Red	Wireless radio is not working properly
n/a	n/a	Amber	Amber	Indicated interface in administrative down state

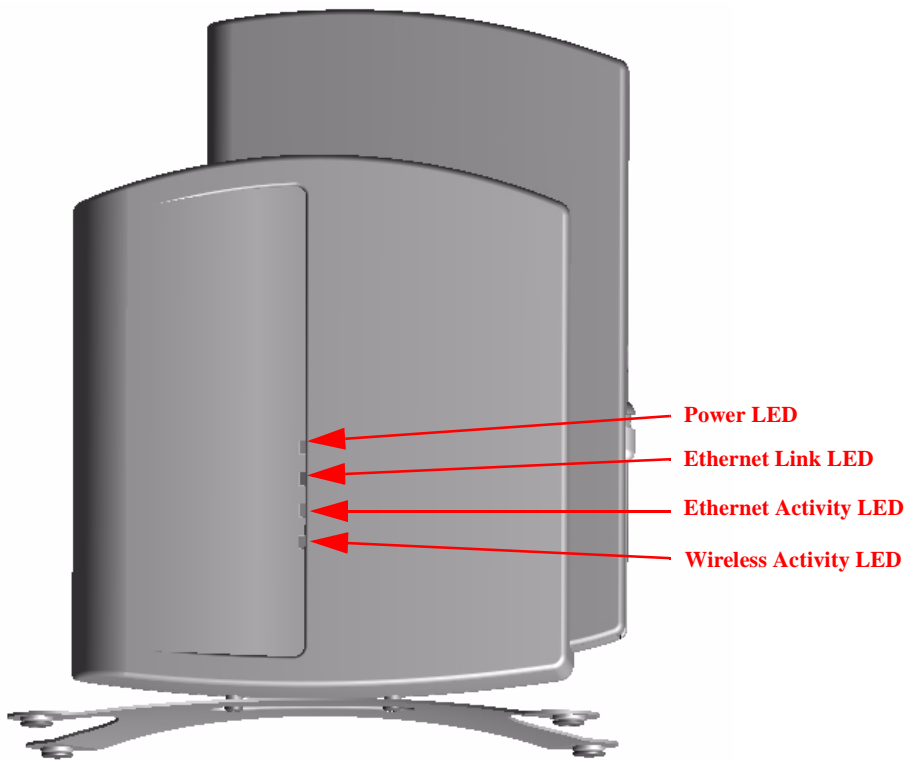

Figure 2-16 LED Indicators Illustrated

Installation & Basic Configuration

Related Topics

The Setup Wizard helps you configure the basic AP-600 settings required to get the unit up and running. The AP-600 supports many other configuration and management options. The remainder of this user guide describes these options in detail.

- See [Advanced Configuration](#) for information on configuration options that are available within the Access Point's HTTP interface.
- See [Monitor Information](#) for information on the statistics displayed within the Access Point's HTTP interface.
- See [Commands](#) for information on the commands supported by the Access Point's HTTP interface.
- See [Troubleshooting](#) for troubleshooting suggestions.
- See [Command Line Interface \(CLI\)](#) for information on the CLI interface and for a list of CLI commands.

3

Status Information

In This Chapter

This chapter describes the statistical information that is reported within the Access Point's HTTP interface.

- [Logging into the HTTP Interface](#)
- [System Status](#)

Logging into the HTTP Interface

Once the AP-600 has a valid IP Address and an Ethernet connection, you may use your web browser to monitor the system status.

Follow these steps to monitor an AP-600's operating statistics using the HTTP interface:

1. Open a Web browser on a network computer.

⇒ NOTE

The HTTP interface supports the following Web browser:

- Microsoft Internet Explorer 5.5 or later
 - Netscape 4.x or later
2. If necessary, disable the Internet proxy settings. For Internet Explorer users, follow these steps:
 - Select **Tools > Internet Options...**
 - Click the **Connections** tab.
 - Click **LAN Settings...**
 - If necessary, remove the check mark from the **Use a proxy server** box.
 - Click **OK** twice to save your changes and return to Internet Explorer.
 3. Enter the Access Point's IP address in the browser's **Address** field and press **Enter**.
 - Result: The **Enter Network Password** screen appears.
 4. Enter the HTTP password in the **Password** field and click **OK**. Leave the **User Name** field blank. (By default, the HTTP password is "public").
 - Result: The **System Status** screen appears.



Figure 3-1 Enter Network Password Screen

System Status

System Status is the first screen to appear each time you connect to the HTTP interface. You can also return to this screen by clicking the **Status** button.

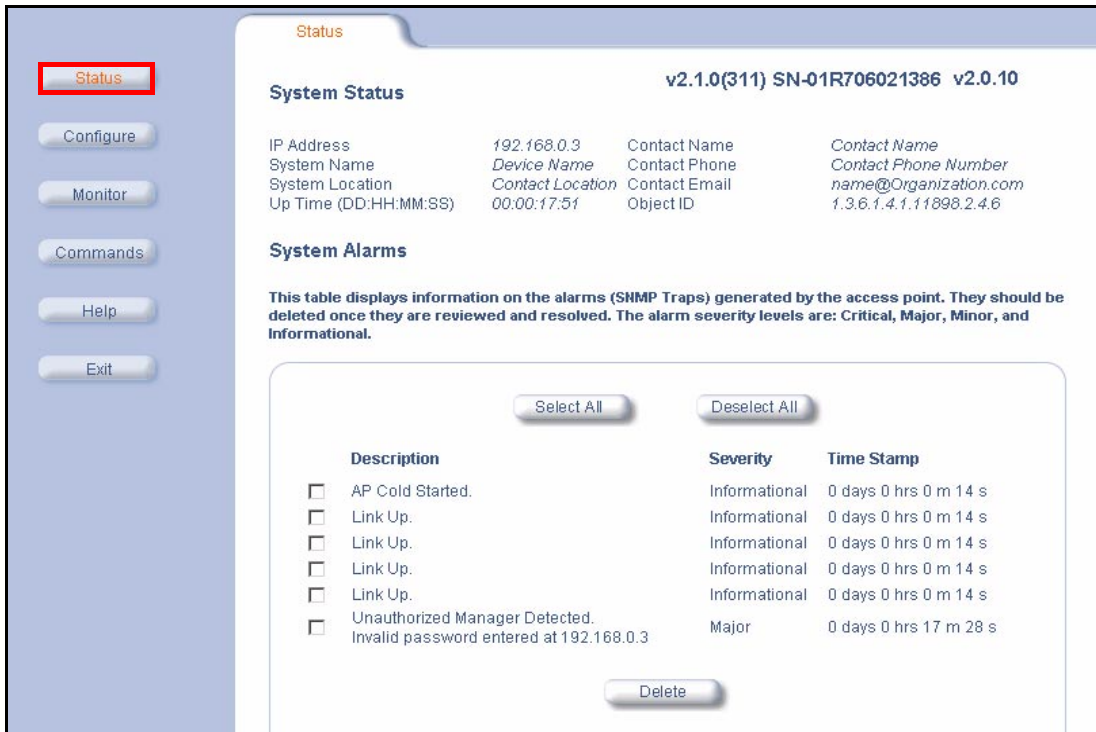

Figure 3-2 System Status Screen

Each section of the **System Status** screen provides the following information:

- **System Status:** This area provides system level information, including the unit's IP address and contact information. See [System](#) for information on these settings.
- **System Alarms:** System traps (if any) appear in this area. Each trap identifies a specific severity level: Critical, Major, Minor, and Informational. See [System Alarms \(Traps\)](#) for a list of possible alarms.

4

Advanced Configuration

In This Chapter

This chapter describes all of the operating parameters that can be configured using the Access Point's HTTP interface.

- [Configuring the AP-600 Using the HTTP Interface](#)
- **System:** Configure specific system information such as system name and contact information.
- **Network:** Configure IP settings, DNS client, DHCP server, and Link Integrity.
- **Interfaces:** Configure the Access Point's interfaces: Wireless and Ethernet.
- **Management:** Configure the Access Point's management Passwords, IP Access Table, and Services.
- **Filtering:** Configure Ethernet Protocol filters, Static MAC Address filters, Advanced filters, and Port filters.
- **Alarms:** Configure the Alarm (SNMP Trap) Groups, the Alarm Host Table, and the Syslog features.
- **Bridge:** Configure the Spanning Tree Protocol, Storm Threshold protection, Intra BSS traffic, and Packet Forwarding.
- **Security:** Configure security features such as MAC Access Control, WEP Encryption, and 802.1x.
- **RADIUS:** Configure RADIUS features such as RADIUS Access Control and Accounting.

Configuring the AP-600 Using the HTTP Interface

Follow these steps to configure an Access Point's operating settings using the HTTP interface:

1. Open a Web browser on a network computer.

NOTE

The HTTP interface supports the following Web browser:

- Microsoft Internet Explorer 5.5 or later
 - Netscape 4.x or later
2. If necessary, disable the Internet proxy settings. For Internet Explorer users, follow these steps:
 - Select **Tools > Internet Options...**
 - Click the **Connections** tab.
 - Click **LAN Settings...**
 - If necessary, remove the check mark from the **Use a proxy server** box.
 - Click **OK** twice to save your changes and return to Internet Explorer.
 3. Enter the Access Point's IP address in the browser's **Address** field and press **Enter**.
 - Result: The **Enter Network Password** screen appears.
 4. Enter the HTTP password in the **Password** field and click **OK**. Leave the **User Name** field blank. (By default, the HTTP password is "public").
 - Result: The **System Status** screen appears.

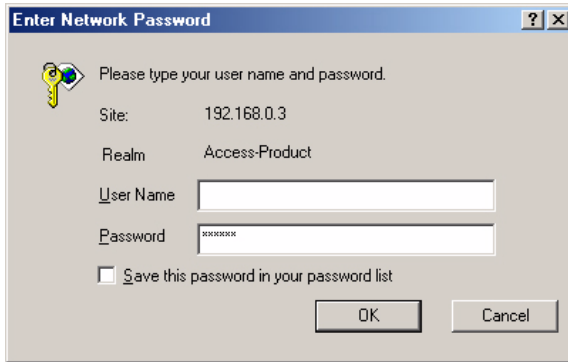

Figure 4-1 Enter Network Password Screen

5. Click the **Configure** button located on the left-hand side of the screen.

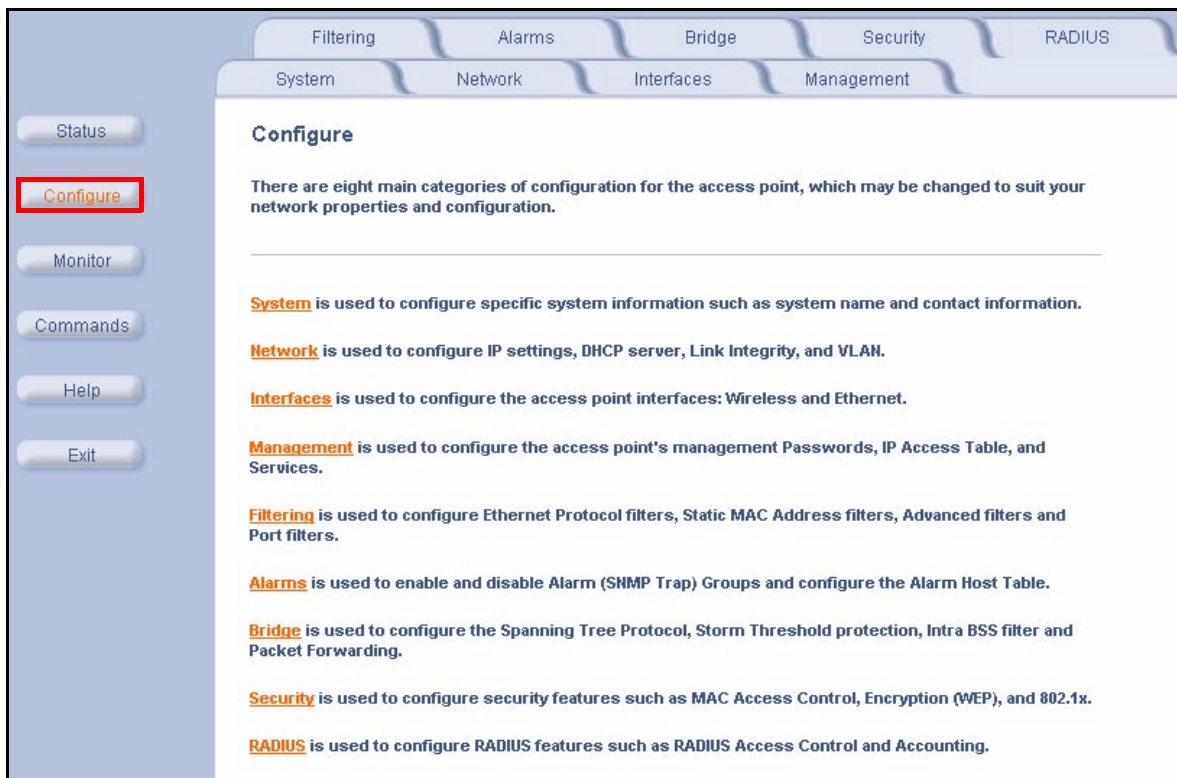

Figure 4-2 Configure Main Screen

6. Click the tab that corresponds to the parameter you want to configure. For example, click **Network** to configure the Access Point's TCP/IP settings. The parameters contained in each of the nine configuration categories are described later in this chapter.
7. Configure the Access Point's parameters as necessary. After changing a configuration value, click **OK** to save the change.
8. Reboot the Access Point for all of the changes to take effect.

Advanced Configuration

System

You can configure and view the following parameters within the **System Configuration** screen:

- **Name:** The name assigned to the AP-600.
- **Location:** The location where the AP-600 is installed.
- **Contact Name:** The name of the person responsible for the AP-600.
- **Contact Email:** The email address of the person responsible for the AP-600.
- **Contact Phone:** The telephone number of the person responsible for the AP-600.
- **Object ID:** This is a read-only field that displays the Access Point's MIB definition; this information is useful if you are managing the AP-600 using SNMP.
- **Ethernet MAC Address:** This is a read-only field that displays the unique MAC (Media Access Control) address for the Access Point's Ethernet interface. The MAC address is assigned at the factory.
- **Descriptor:** This is a read-only field that reports the Access Point's name, serial number, current image software version, and current bootloader software version.
- **Up Time:** This is a read-only field that displays how long the Access Point has been running since its last reboot.

Network

The Network category contains three sub-categories.

- [IP Configuration](#)
- [DHCP Server](#)
- [Link Integrity](#)

IP Configuration

You can configure and view the following parameters within the **IP Configuration** screen:



NOTE

You must reboot the Access Point in order for any changes to the Basic IP or DNS Client parameters take effect.

Basic IP Parameters

- **IP Address Assignment Type:** Set this parameter to **Dynamic** to configure the Access Point as a Dynamic Host Configuration Protocol (DHCP) client; the Access Point will obtain IP settings from a network DHCP server automatically during boot-up. If you do not have a DHCP server or if you want to manually configure the Access Point's IP settings, set this parameter to **Static**.
- **IP Address:** The Access Point's IP address. When IP Address Assignment Type is set to Dynamic, this field is read-only and reports the unit's current IP address. The Access Point will default to 169.254.128.132 if it cannot obtain an address from a DHCP server.
- **Subnet Mask:** The Access Point's subnet mask. When IP Address Assignment Type is set to Dynamic, this field is read-only and reports the unit's current subnet mask. The subnet mask will default to 255.255.0.0 if the unit cannot obtain one from a DHCP server.
- **Gateway IP Address:** The IP address of the Access Point's gateway. When IP Address Assignment Type is set to Dynamic, this field is read-only and reports the IP address of the unit's gateway. The gateway IP address will default to 169.254.128.133 if the unit cannot obtain an address from a DHCP server.

DNS Client

If you prefer to use host names to identify network servers rather than IP addresses, you can configure the AP-600 to act as a Domain Name Service (DNS) client. When this feature is enabled, the Access Point contacts the network's DNS server to translate a host name to the appropriate network IP address. You can use this DNS Client functionality to identify RADIUS servers by host name. See [RADIUS](#) for details.

- **Enable DNS Client:** Place a check mark in the box provided to enable DNS client functionality. Note that this option must be enabled before you can configure the other DNS Client parameters.
- **DNS Primary Server IP Address:** The IP address of the network's primary DNS server.

Advanced Configuration

- **DNS Secondary Server IP Address:** The IP address of a second DNS server on the network. The Access Point will attempt to contact the secondary server if the primary server is unavailable.
- **DNS Client Default Domain Name:** The default domain name for the Access Point's network (for example, "proxim.com"). Contact your network administrator if you need assistance setting this parameter.

Advanced

- **Default TTL (Time to Live):** Time to Live (TTL) is a field in an IP packet that specifies how long in seconds the packet can remain active on the network. The Access Point uses the default TTL for packets it generates for which the transport layer protocol does not specify a TTL value. This parameter supports a range from 0 to 65535. By default, TTL is 64.

DHCP Server

If your network does not have a DHCP Server, you can configure the AP-600 as a DHCP server to assign dynamic IP addresses to Ethernet nodes and wireless clients.



CAUTION

Make sure there are no other DHCP servers on the network and do not enable the DHCP server without checking with your network administrator first, as it could bring down the whole network. Also, the AP-600 must be configured with a static IP address before enabling this feature.

When the DHCP Server functionality is enabled, you can create one or more IP address pools from which to assign addresses to network devices.

The screenshot shows the DHCP Server configuration interface. At the top, there are tabs for Filtering, Alarms, Bridge, Security, and RADIUS. Below these are tabs for System, Network, Interfaces, and Management. The Network tab is selected, and within it, the DHCP Server sub-tab is active. The interface includes a sidebar with buttons for Status, Configure, Monitor, Commands, Help, and Exit. The main content area contains the following configuration options:

- Enable DHCP Server:
- Subnet Mask: 255.255.255.0
- Gateway IP Address: 192.168.0.100
- Primary DNS IP Address: 192.168.0.1
- Secondary DNS IP Address: 192.168.0.2
- Number of IP Pool Table Entries: 1

Below the configuration options are OK and Cancel buttons. Underneath is the IP Pool Table section, which includes Add and Edit buttons and a table with the following data:

Start IP	End IP	Default Lease	Maximum Lease	Comment	Status
192.168.0.102	192.168.0.110	86400	86400		Enable

Figure 4-3 DHCP Server Configuration Screen

Advanced Configuration

You can configure and view the following parameters within the **DHCP Server Configuration** screen:

- **Enable DHCP Server:** Place a check mark in the box provided to enable DHCP Server functionality.

NOTE

You cannot enable the DHCP Server functionality unless there is at least one IP Pool Table Entry configured.

- **Subnet Mask:** This field is read-only and reports the Access Point's current subnet mask. DHCP clients that receive dynamic addresses from the AP-600 will be assigned this same subnet mask.
- **Gateway IP Address:** The AP-600 will assign the specified address to its DHCP clients.
- **Primary DNS IP Address:** The AP-600 will assign the specified address to its DHCP clients.
- **Secondary DNS IP Address:** The AP-600 will assign the specified address to its DHCP clients.
- **Number of IP Pool Table Entries:** This is a read-only field that reports the number of IP address pools currently configured.
- **IP Pool Table Entry:** This entry specifies a range of IP addresses that the AP can assign to its wireless clients. Click **Add** to create a new entry. Click **Edit** to change an existing entry. Each entry contains the following field:
 - **Start IP Address**
 - **End IP Address**
 - **Default Lease Time (optional):** The default time value for clients to retain the assigned IP address. DHCP automatically renews IP Addresses without client notification. This parameter supports a range between 0 and 86400 seconds. The default is 86400 seconds.
 - **Maximum Lease Time (optional):** The maximum time value for clients to retain the assigned IP address. DHCP automatically renews IP Addresses without client notification. This parameter supports a range between 0 and 86400 seconds. The default is 86400 seconds.
 - **Comment (optional)**
 - **Status:** IP Pools are enabled upon entry in the table. You can also disable or delete entries by changing this field's value.

NOTE

You must reboot the Access Point before changes to any of these DHCP server parameters take effect.

Link Integrity

The Link Integrity feature checks the link between the AP-600 and the nodes on the Ethernet backbone. These nodes are listed by IP address in the Link Integrity IP Address Table. The AP-600 periodically pings the nodes listed within the table. If the AP-600 loses network connectivity (that is, the ping attempts fail), the AP-600 disables its wireless interface until the connection is restored. This forces the unit's wireless clients to switch to another Access Point that still has a network connection. Note that this feature does not affect WDS links (if applicable).

You can configure and view the following parameters within the **Link Integrity Configuration** screen:

- **Enable Link Integrity:** Place a check mark in the box provided to enable Link Integrity.
- **Poll Interval (milliseconds):** The interval between link integrity checks. Range is 500 - 15000 ms in increments of 500 ms; default is 500 ms.
- **Poll Retransmissions:** The number of times a poll should be retransmitted before the link is considered down. Range is 0 to 255; default is 5.
- **Target IP Address Entry:** This entry specifies the IP address of a host on the network that the AP-600 will periodically poll to confirm connectivity. The table can hold up to five entries. By default, all five entries are set to 0.0.0.0. Click **Edit** to update one or more entries. Each entry contains the following field:
 - **Target IP Address**
 - **Comment (optional)**
 - **Status:** Set this field to **Enable** to specify that the Access Point should poll this device. You can also disable an entry by changing this field's value to **Disable**.

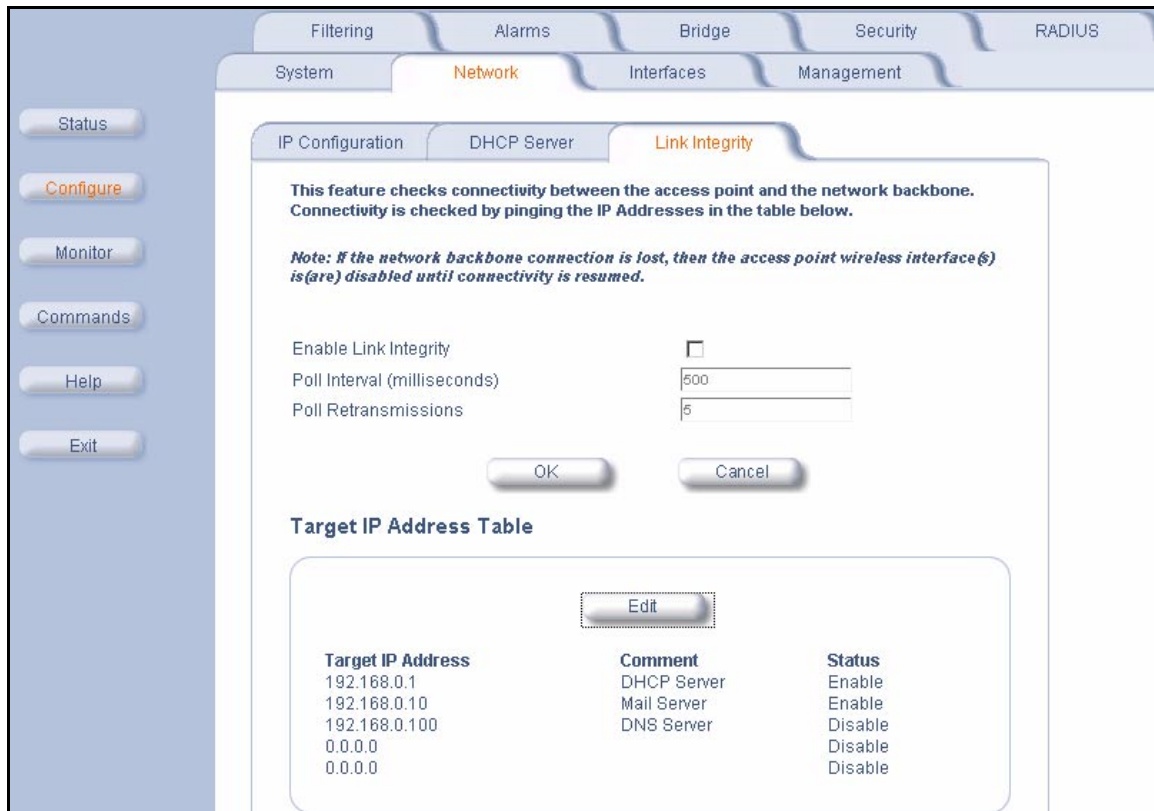

Figure 4-4 Link Integrity Configuration Screen

Interfaces

From the **Interfaces** tab, you configure the Access Point's radio and Ethernet settings. Refer to the Wireless parameters below that correspond to your Access Point model (AP-600a or AP-600b). The Ethernet settings apply to both models.

- [Wireless \(AP-600a\)](#)
- [Wireless \(AP-600b\)](#)
- [Ethernet](#)

Wireless (AP-600a)

You can configure and view the following parameters within the **Wireless Interface Configuration** screen for an AP-600a:

NOTE

You must reboot the Access Point before any changes to these parameters take effect.

- **Physical Interface Type:** For the AP-600a, this field reports: "802.11a (OFDM 5 GHz)." OFDM stands for Orthogonal Frequency Division Multiplexing; this is the name for the radio technology used by 802.11a devices.
- **MAC Address:** This is a read-only field that displays the unique MAC (Media Access Control) address for the Access Point's wireless interface. The MAC address is assigned at the factory.

Advanced Configuration

- **Regulatory Domain:** Reports the regulatory domain for which the AP-600a is certified. Not all features or channels are available in all countries. The available regulatory domains include:
 - U.S./Canada -- FCC (5.15-5.35 GHz, 5.725-5.850 GHz)
 - Europe -- ETSI (5.15-5.25 GHz only)
 - Europe -- ETSI (5.15-5.35 GHz)
 - Japan -- MMK (5.15-5.25 GHz)
 - Singapore (5.15-2.25 GHz, 5.725-5.850 GHz)
- **Network Name (SSID):** Enter a Network Name (between 2 and 31 characters long) for the wireless network. You must configure each wireless client to use this name as well.
- **Auto Channel Select:** The AP-600a scans the area for other Access Points and selects a free or relatively unused communication channel. This helps prevent interference problems and increases network performance. By default this feature is enabled. Note that you cannot disable Auto Channel Select for 802.11a products in Europe (see [Dynamic Frequency Selection \(DFS\)](#) for details). See [802.11a Channel Frequencies for the AP-600a](#) for a list of Channels.
- **Turbo Mode:** The AP-600a supports 2X Turbo Mode, an extension of the IEEE 802.11a standard that provides twice the data rate. Note that 2X Turbo mode is not defined in the IEEE 802.11a specification. By default, Turbo mode is disabled. Turbo mode is not available in all countries.
- **Frequency Channel:** When Auto Channel Select is enabled, this field is read-only and displays the Access Point's current operating channel. When Auto Channel Select is disabled, you can specify the Access Point's channel. If you decide to manually set the unit's Channel, ensure that nearby devices do not use the same frequency. Available Channels vary based on regulatory domain and the Turbo Mode setting. See [802.11a Channel Frequencies for the AP-600a](#). Note that you cannot manually set the channel for 802.11a products in Europe (see [Dynamic Frequency Selection \(DFS\)](#) for details).
- **Transmit Rate:** Use the drop-down menu to select a specific transmit rate for the AP-600a. Choose between 6, 9, 12, 18, 24, 36, 48, 54 Mbits/s, and Auto Fallback for standard 802.11a mode. If Turbo mode is enabled, choose between 12, 18, 24, 36, 48, 72, 98, 108 Mbits/s, and Auto Fallback. Auto Fallback is the default setting; it allows the AP-600a unit to select the best transmit rate based on the cell size.

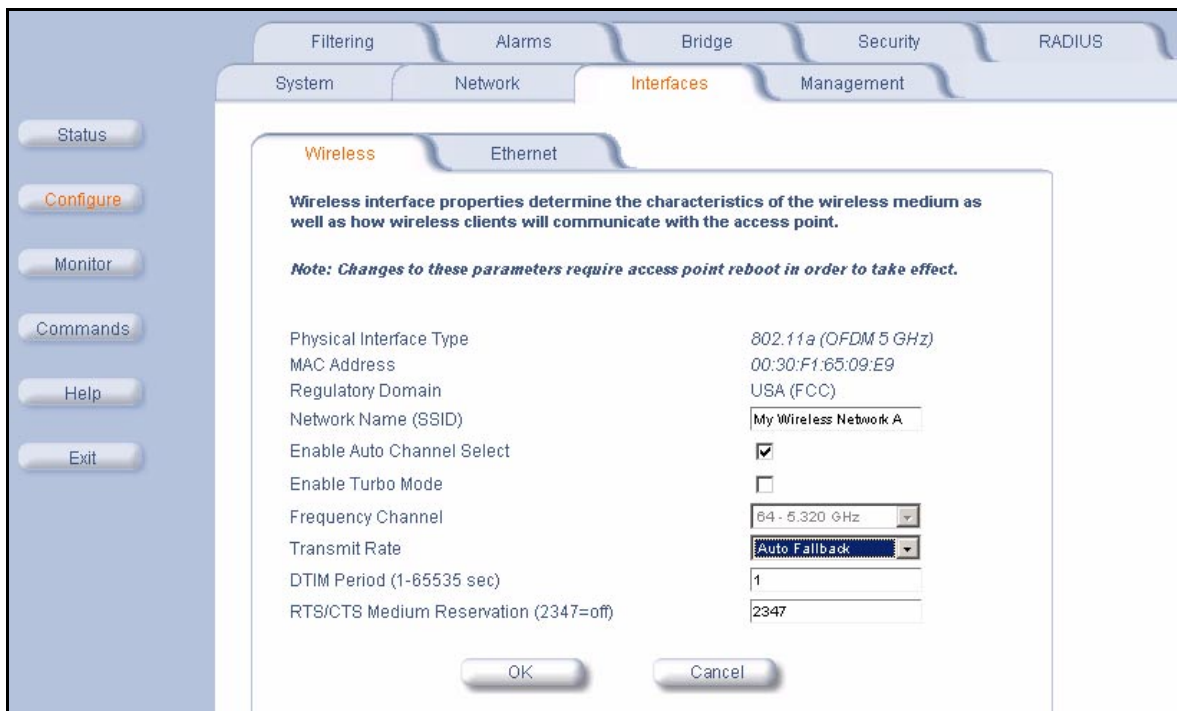

Figure 4-5 Wireless Interface Configuration Screen (AP-600a)

Advanced Configuration

- **DTIM Period:** The Deferred Traffic Indicator Map (DTIM) is used with clients that have power management enabled. DTIM should be left at 1, the default value, if any clients have power management enabled. This parameter supports a range between 1 and 65535.
- **RTS/CTS Medium Reservation:** This parameter affects message flow control and should not be changed under normal circumstances. Range is 0 to 2347. When set to a value between 0 and 2347, the Access Point uses the RTS/CTS mechanism for packets that are the specified size or greater. When set to 2347 (the default setting), RTS/CTS is disabled. See [RTS/CTS Medium Reservation](#) for more information.

Dynamic Frequency Selection (DFS)

AP-600a units sold in Europe use a technique called Dynamic Frequency Selection (DFS) to automatically select an operating channel. During boot-up, the AP-600a scans the available frequency and selects a channel that is free of interference. If the AP-600a subsequently detects interference on its channel, it automatically reboots and selects another channel that is free of interference.

DFS only applies to AP-600a devices used in Europe (i.e., units whose regulatory domain is set to ETSI). The European Telecommunications Standard Institute (ETSI) requires that 802.11a devices use DFS to prevent interference with radar systems and other devices that already occupy the 5 GHz band.

If you are using an AP-600a in Europe, keep in mind the following:

- DFS is not a configurable parameter. It is always enabled and cannot be disabled.
- You cannot manually select the device's operating channel; you must let DFS select the channel.
- You cannot configure the **Auto Channel Select** option. Within the HTTP interface, this option always appears enabled.

RTS/CTS Medium Reservation

The 802.11 standard supports optional RTS/CTS communication based on packet size. Without RTS/CTS, a sending radio listens to see if another radio is already using the medium before transmitting a data packet. If the medium is free, the sending radio transmits its packet. However, there is no guarantee that another radio is not transmitting a packet at the same time, causing a collision. This typically occurs when there are hidden nodes (clients that can communicate with the Access Point but are out of range of each other) in very large cells.

When RTS/CTS occurs, the sending radio first transmits a Request to Send (RTS) packet to confirm that the medium is clear. When the receiving radio successfully receives the RTS packet, it transmits back a Clear to Send (CTS) packet to the sending radio. When the sending radio receives the CTS packet, it sends the data packet to the receiving radio. The RTS and CTS packets contain a reservation time to notify other radios (including hidden nodes) that the medium is in use for a specified period. This helps to minimize collisions. While RTS/CTS adds overhead to the radio network, it is particularly useful for large packets that take longer to resend after a collision occurs.

RTS/CTS Medium Reservation is an advanced parameter and supports a range between 0 and 2347 bytes. When set to 2347 (the default setting), the RTS/CTS mechanism is disabled. When set to 0, the RTS/CTS mechanism is used for all packets. When set to a value between 0 and 2347, the Access Point uses the RTS/CTS mechanism for packets that are the specified size or greater. You should not need to enable this parameter for most networks unless you suspect that the wireless cell contains hidden nodes.

Wireless (AP-600b)

You can configure and view the following parameters within the **Wireless Interface Configuration** screen for an AP-600b:

NOTE

You must reboot the Access Point before any changes to these parameters take effect.

- **Physical Interface Type:** For the AP-600b, this field reports: "802.11b (DSSS 2.4 GHz)." DSSS stands for Direct Sequence Spread Spectrum; this is the name for the radio technology used by 802.11b devices.
- **MAC Address:** This is a read-only field that displays the unique MAC (Media Access Control) address for the Access Point's wireless interface. The MAC address is assigned at the factory.

Advanced Configuration

- **Regulatory Domain:** Reports the regulatory domain for which the AP-600b is certified. Not all features or channels are available in all countries. The available regulatory domains include:
 - U.S./Canada -- FCC (2.4000-2.4835 GHz)
 - Europe -- ETSI (2.4000-2.4835 GHz; France only: 2.4465-2.4835 GHz)
 - Japan -- MKK (2.4000 GHz-2.4970 GHz)
- **Network Name (SSID):** Enter a Network Name (between 2 and 31 characters long) for the wireless network. You must configure each wireless client to use this name as well.
- **Auto Channel Select:** The AP-600b scans the area for other Access Points and selects a free or relatively unused communication channel. This helps prevent interference problems and increases network performance. By default this feature is enabled; see [802.11b Channel Frequencies for the AP-600b](#) for a list of Channels. However, if you are setting up a Wireless Distribution System (WDS), it must be disabled. See [Wireless Distribution System \(WDS\)](#) for more information.
- **Frequency Channel:** When Auto Channel Select is enabled, this field is read-only and displays the Access Point's current operating channel. When Auto Channel Select is disabled, you can specify the Access Point's operating channel. If you decide to manually set the unit's channel, ensure that nearby devices do not use the same frequency (unless you are setting up a WDS). Available Channels vary based on regulatory domain. See [802.11b Channel Frequencies for the AP-600b](#).
- **Distance Between APs:** Set to **Large**, **Medium**, **Small**, **Microcell**, or **Minicell** depending on the site survey for your system. By default, this parameter is set to **Large**. The distance value is related to the **Multicast Rate** (described next). In general, a larger distance between APs means that your clients operate a slower data rates (on average). See [Distance Between APs](#) for more information.

The screenshot displays the 'Wireless' configuration page within a web interface. At the top, there are tabs for 'Filtering', 'Alarms', 'Bridge', 'Security', and 'RADIUS'. Below these are sub-tabs for 'System', 'Network', 'Interfaces', and 'Management'. The 'Interfaces' tab is active, and within it, the 'Wireless' sub-tab is selected. The page contains a descriptive paragraph about wireless interface properties, a warning about WDS, and a note about rebooting. The configuration table below lists various parameters and their current values or settings.

Wireless Interface Type	802.11b (DSSS 2.4 GHz)
MAC Address	00:02:2D:7F:18:77
Regulatory Domain	
Network Name (SSID)	My Wireless Network
Enable Auto Channel Select	<input checked="" type="checkbox"/>
Frequency Channel	7 - 2.442 GHz
Distance Between APs	Large
Multicast Rate	2 Mbit/Sec
DTIM Period (1-65535 sec)	1
RTS/CTS Medium Reservation (2347=off)	2347
Enable Interference Robustness	<input type="checkbox"/>
Enable Closed System	<input type="checkbox"/>
Enable Load Balancing	<input checked="" type="checkbox"/>
Enable Medium Density Distribution	<input checked="" type="checkbox"/>

At the bottom of the configuration area, there are 'OK' and 'Cancel' buttons.

Figure 4-6 Wireless Interface Configuration Screen (AP-600b)

Advanced Configuration

- Multicast Rate:** Sets the rate at which Multicast messages are sent. This value is related to the Distance Between APs parameter (described previously). The table below displays the possible Multicast Rates based on the Distance between APs setting. By default, this parameter is set to 2 Mbits/sec. See [Multicast Rate](#) for more information.

Distance between APs	Multicast Rate
Large	1 and 2 Mbits/sec
Medium	1, 2, and 5.5 Mbits/sec
Small	1, 2, 5.5 and 11 Mbits/sec
Minicell	1, 2, 5.5 and 11 Mbits/sec
Microcell	1, 2, 5.5 and 11 Mbits/sec

- DTIM Period:** The Deferred Traffic Indicator Map (DTIM) is used with clients that have power management enabled. DTIM should be left at 1, the default value, if any clients have power management enabled. This parameter supports a range between 1 and 65535.
- RTS/CTS Medium Reservation:** This parameter affects message flow control and should not be changed under normal circumstances. Range is 0 to 2347. When set to a value between 0 and 2347, the Access Point uses the RTS/CTS mechanism for packets that are the specified size or greater. When set to 2347 (the default setting), RTS/CTS is disabled. See [RTS/CTS Medium Reservation](#) for more information.
- Interference Robustness:** Enable this option if other electrical devices in the 2.4 GHz frequency band (such as a microwave oven or a cordless phone) may be interfering with the wireless signal. The AP-600b will automatically fragment large packets into multiple smaller packets when interference is detected to increase the likelihood that the messages will be received in the presence of interference. The receiving radio reassembles the original packet once all fragments have been received. This option is disabled by default.
- Closed System:** Check this box to allow only clients configured with the Access Point's specific Network Name to associate with the Access Point. When enabled, a client configured with the Network Name "ANY" cannot connect to the AP-600b. This option is disabled by default.
- Load Balancing:** Enable this option so clients can evaluate which Access Point to associate with, based on current AP loads. This feature is enabled by default; it helps distribute the wireless load between APs. This feature is not available if you are using an ORiNOCO 802.11a/b ComboCard or a non-ORiNOCO client with the AP-600b.
- Medium Density Distribution:** When enabled, the Access Point automatically notifies wireless clients of its **Distance Between APs**, **Interference Robustness**, and **RTS/CTS Medium Reservation** settings. This feature is enabled by default and allows clients to automatically adopt the values used by its current Access Point (even if these values differ from the client's default values or from the values supported by other Access Points). Note that this feature is not available if you are using an ORiNOCO 802.11a/b ComboCard or a non-ORiNOCO client with the AP-600b. Proxim recommends that you leave this parameter enabled, particularly if you have ORiNOCO clients on your wireless network (leaving this parameter enabled should not adversely affect the performance of any ORiNOCO 802.11a/b ComboCards or non-ORiNOCO cards on your network).

Distance Between APs

Distance Between APs defines how far apart (physically) your AP-600b devices are located, which in turn determines the size of your cell. Cells of different sizes have different capacities and, therefore, suit different applications. For instance, a typical office has many stations that require high bandwidth for complex, high-speed data processing. In contrast, a typical warehouse has a few forklifts requiring low bandwidth for simple transactions.

NOTE

This feature is not available if you are using an ORiNOCO 802.11a/b ComboCard or a non-ORiNOCO client with the AP-600b.

Cell capacities are compared in the following table, which shows that small cells suit most offices and large cells suit most warehouses:

Small Cell	Large Cell
Physically accommodates few stations	Physically accommodates many stations
High cell bandwidth per station	Lower cell bandwidth per station
High transmit rate	Lower transmit rate

Advanced Configuration

Coverage

The number of Access Points in a set area determines the network coverage for that area. A large number of Access Points covering a small area is a high-density cell. A few Access Points, or even a single unit, covering the same small area would result in a low-density cell, even though in both cases the actual area did not change — only the number of Access Points covering the area changed.

In a typical office, a high density area consists of a number of Access Points installed every 20 feet and each Access Point generates a small radio cell with a diameter of about 10 feet. In contrast, a typical warehouse might have a low density area consisting of large cells (with a diameter of about 90 feet) and Access Points installed every 200 feet.

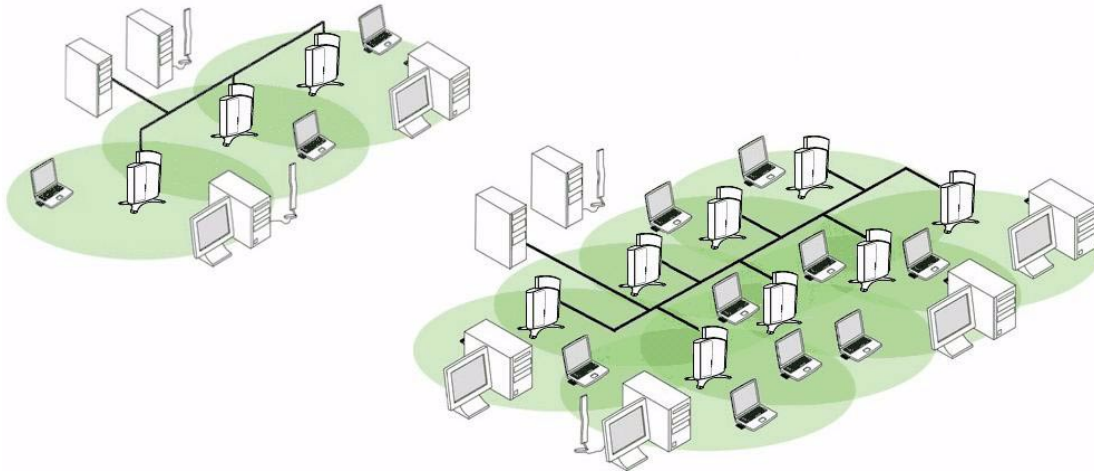

Figure 4-7 Low Density vs. Ultra High Density Network

The Distance Between Cells parameter supports five values: Large, Medium, Small, Minicell, and Microcell.



CAUTION

The distance between APs should not be approximated. It is calculated by means of a manual Site Survey, in which an AP-600b is set up and clients are tested throughout the area to determine signal strength and coverage, and local limits such as physical interference are investigated. From these measurements the appropriate cell size and density is determined, and the optimum distance between APs is calculated to suit your particular business requirements. Contact your reseller for information on how to conduct a Site Survey.

Multicast Rate

The multicast rate determines the rate at which broadcast and multicast packets are transmitted by the Access Point to the wireless network. Stations that are closer to the Access Point can receive multicast packets at a faster data rate than stations that are farther away from the AP. Therefore, you should set the Multicast Rate based on the size of the Access Point's cell. For example, if the Access Point's cell is very small (e.g., Distance Between APs is set to Microcell), you can expect that all stations should be able to successfully receive multicast packets at 11 MBits/sec so you can set Multicast Rate to 11 Mbits/sec. However, if the Access Point's cell is large, you need to accommodate stations that may not be able to receive multicast packets at the higher rates; in this case, you should set Multicast Rate to 1 or 2 Mbits/sec.

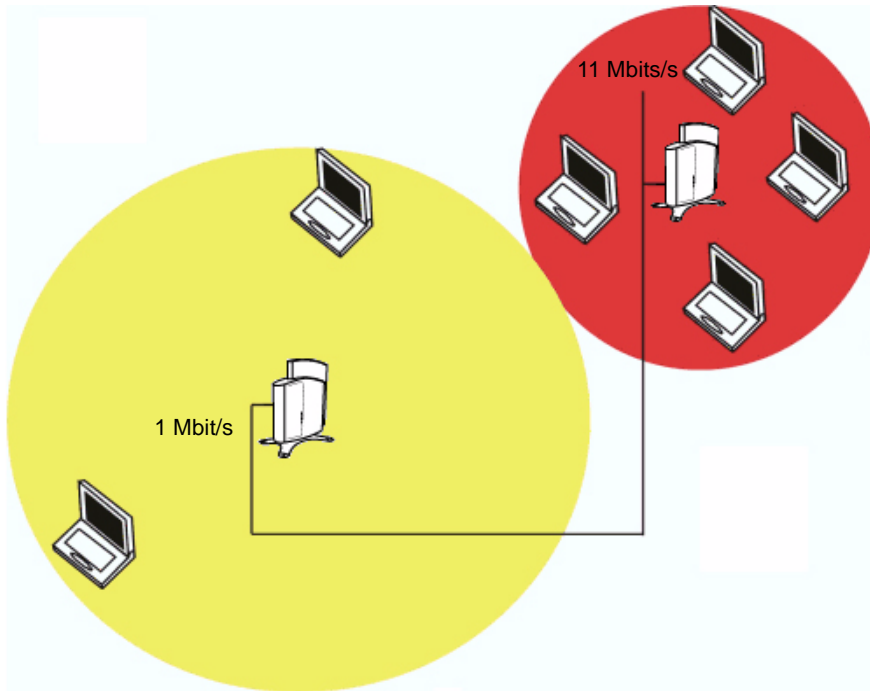

Figure 4-8 1 Mbit/s and 11 Mbits/s Multicast Rates

NOTE

There is an inter-dependent relationship between the Distance between APs and the Multicast Rate. In general, larger systems operate at a lower average transmit rate. The variation between Multicast Rate and Distance Between APs is presented in the following table:

	1.0 Mbit/s	2.0 Mbits/s	5.5 Mbits/s	11 Mbits/s
Large	yes	yes		
Medium	yes	yes	yes	
Small	yes	yes	yes	yes
Minicell	yes	yes	yes	yes
Microcell	yes	yes	yes	yes

The Distance Between APs **must be set before** the Multicast Rate, because when you select the Distance Between APs, the appropriate range of Multicast values automatically populates the drop-down menu. This feature is not available if you are using an ORiNOCO 802.11a/b ComboCard or a non-ORiNOCO client with the AP-600b.

Wireless Distribution System (WDS)

A Wireless Distribution System (WDS) creates a link between two AP-600b units over their radio interfaces. This link relays traffic from one AP-600b that does not have Ethernet connectivity to a second AP-600b that has Ethernet connectivity. WDS allows you to configure up to six (6) point-to-point links between Access Points.

In the [WDS Example](#) below, AP 1 and AP 2 communicate over a WDS link (represented by the blue line). This link provides Client 1 with access to network resources even though AP 1 is not directly connected to the Ethernet network. Packets destined for or sent by the client are relayed between the Access Points over the WDS link.

NOTE

This feature is not available with the AP-600a.

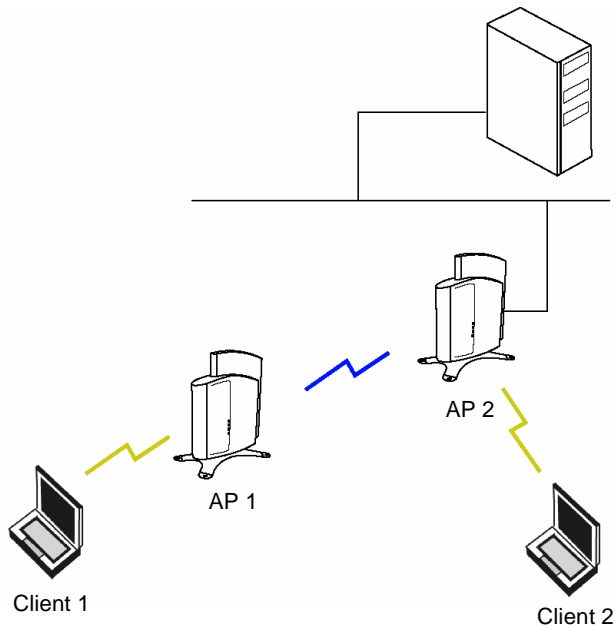

Figure 4-9 WDS Example

Bridging WDS

Each WDS link is mapped to a logical WDS port on the AP-600b. WDS ports behave like Ethernet ports rather than like standard wireless interfaces: on a BSS port, an Access Point learns by association and from frames; on a WDS or Ethernet port, an Access Point learns from frames only. When setting up a WDS, keep in mind the following:

- The WDS link shares the communication bandwidth with the clients. Therefore, while the maximum data rate for the Access Point's cell is still 11 Mb, client throughput will decrease when the WDS link is active.
- If there is no partner MAC address configured in the WDS table, the WDS port remains disabled.
- Each WDS port on a single AP-600b should have a unique partner MAC address. Do not enter the same MAC address twice in an AP-600b's WDS port list.
- Each Access Point that is a member of the WDS must have the same Channel setting to communicate with each other.
- Each Access Point that is a member of the WDS must have the same WEP Encryption settings. WDS does not use 802.1x. Therefore, if you want to encrypt the WDS link, you must configure each Access Point to use WEP encryption (either WEP encryption only or Mixed Mode), and each Access Point must have the same Encryption Key(s). See [Security](#).
- If your network does not support spanning tree, be careful to avoid creating network loops between AP-600b devices. For example, creating a WDS link between two Access Points connected to the same Ethernet network will create a network loop (if spanning tree is disabled).

WDS Setup Procedure

➤ NOTE

You must disable Auto Channel Select to create a WDS.

To setup a wireless backbone follow the steps below for each AP-600b that you wish to include in the Wireless Distribution System.

1. Confirm that Auto Channel Select is disabled.
2. Write down the MAC Address of the radio that you wish to include in the Wireless Distribution System.
3. Open the **Wireless Interface Configuration** screen.
4. Scroll down to the **Wireless Distribution System** heading.
5. Click the **Edit** button to update the Wireless Distribution System (WDS) Table.

Advanced Configuration

6. Enter the MAC Address that you wrote down in Step 2 in one of the **Partner MAC Address** field of the Wireless Distribution Setup window.
7. Set the **Status** of the device to **Enable**.
8. Click **OK**.

Wireless Distribution System (WDS)

WDS can be used to establish point-to-point (i.e. wireless backhaul) connections with other access points. This table is used to configure WDS partner access points.

Port Index	Partner MAC Address	Status
1	00:02:2D:12:34:56	Disable
2	00:00:00:00:00:00	Disable
3	00:00:00:00:00:00	Disable
4	00:00:00:00:00:00	Disable
5	00:00:00:00:00:00	Disable
6	00:00:00:00:00:00	Disable

Figure 4-10 WDS Configuration

9. Restart the AP-600b.



NOTE

To set up a Wireless Distribution System (WDS) with 802.1x, set each Access Point's 802.1x Security Mode to Mixed and assign each unit in the WDS the same Encryption Key 1. See [Security](#).

Ethernet

Select the desired speed and transmission mode from the drop-down menu. Half-duplex means that only one side can transmit at a time and full-duplex allows both sides to transmit. When set to auto-duplex, the AP-600 negotiates with its switch or hub to automatically select the highest throughput option supported by both sides.

For best results, Proxim recommends that you configure the Ethernet setting to match the speed and transmission mode of the device the Access Point is connected to (such as a hub or switch). If in doubt, leave this setting at its default, **auto-speed-auto-duplex**. Choose between:

- 10 Mbit/s - half duplex, full duplex, or auto duplex
- 100 Mbit/s - half duplex, full duplex, or auto duplex
- auto speed - half duplex or auto duplex

Advanced Configuration

Management

The Management category contains three sub-categories.

- [Passwords](#)
- [IP Access Table](#)
- [Services](#)

Passwords

You can configure the following passwords:

- **SNMP Read Password:** The password for read access to the AP-600 using SNMP. Enter a password in both the **Password** field and the **Confirm** field. The default password is “public”.
- **SNMP Read/Write Password:** The password for read and write access to the AP-600 using SNMP. Enter a password in both the **Password** field and the **Confirm** field. The default password is “public”.
- **Telnet (CLI) Password:** The password for the CLI interface (via serial or Telnet). Enter a password in both the **Password** field and the **Confirm** field. The default password is “public”.
- **HTTP (Web) Password:** The password for the Web browser HTTP interface. Enter a password in both the **Password** field and the **Confirm** field. The default password is “public”.

NOTE

For security purposes Proxim recommends changing ALL PASSWORDS from the default “public” immediately, to restrict access to your network devices to authorized personnel. If you lose or forget your password settings, you can always perform the [Reset to Factory Default Procedure](#).

IP Access Table

The Management IP Access table limits in-band management access to the IP addresses or range of IP addresses specified in the table. This feature applies to all management options (SNMP, HTTP, and CLI) except for CLI management over the serial port. To configure this table, click **Add** and set the following parameters:

- **IP Address:** Enter the IP Address for the management station.
- **IP Mask:** Enter a mask that will act as a filter to limit access to a range of IP Addresses based on the IP Address you already entered.
 - The IP mask 255.255.255.255 would authorize the single station defined by the IP Address to configure the Access Point. The AP-600 would ignore commands from any other IP address. In contrast, the IP mask 255.255.255.0 would allow any device that shares the first three octets of the IP address to configure the AP-600. For example, if you enter an IP address of 10.20.30.1 with a 255.255.255.0 subnet mask, any IP address between 10.20.30.1 and 10.20.30.254 will have access to the AP's management interfaces.
- **Comment:** Enter an optional comment, such as the station name.

To edit or delete an entry, click **Edit**. Edit the information, or select **Enable**, **Disable**, or **Delete** from the **Status** pull-down menu.

Advanced Configuration

Services

You can configure the following management services:

➤ NOTE

You must reboot the Access Point if you change the HTTP Port or Telnet Port.

SNMP Settings

- **SNMP Interface Bitmask:** Configure the interface or interfaces (**Ethernet, Wireless, All Interfaces**) from which you will manage the AP-600 via SNMP. You can also select **Disabled** to prevent a user from accessing the AP-600 device via SNMP.

HTTP Access

- **HTTP Interface Bitmap:** Configure the interface or interfaces (**Ethernet, Wireless, All Interfaces**) from which you will manage the AP-600 via the Web interface. For example, to allow Web configuration via the Ethernet network only, set **HTTP Interface Bitmask** to **Ethernet**. You can also select **Disabled** to prevent a user from accessing the AP-600 from the Web interface.
- **HTTP Port:** Configure the HTTP port from which you will manage the AP-600 via the Web interface. By default, the HTTP port is 80.

The screenshot shows the 'Management Services' configuration screen. The interface has a sidebar on the left with buttons for 'Status', 'Configure', 'Monitor', 'Commands', 'Help', and 'Exit'. The main content area has tabs for 'Filtering', 'Alarms', 'Bridge', 'Security', and 'RADIUS'. Under 'Management', there are sub-tabs for 'System', 'Network', 'Interfaces', and 'Management'. The 'Services' sub-tab is active, showing a note: 'This tab is used to configure SNMP, Telnet (CLI), and HTTP (web) parameters. Note: Changes to these parameters require access point reboot in order to take effect.' The configuration fields are as follows:

SNMP Interface Bitmask	Ethernet
HTTP Interface Bitmask	All Interfaces
HTTP Port	80
Telnet Interface Bitmask	Wireless
Telnet Port Number	23
Telnet Login Idle Timeout (seconds)	30
Telnet Session Idle Timeout (seconds)	900
Serial Baud Rate	9600
Serial Flow Control	None
Serial Data Bits	8
Serial Parity	None
Serial Stop Bits	1

At the bottom of the form are 'OK' and 'Cancel' buttons.

Figure 4-11 Management Services Configuration Screen

Advanced Configuration

Telnet Configuration Settings

- **Telnet Interface Bitmask:** Select the interface (**Ethernet, Wireless, All Interfaces**) from which you can manage the AP-600 via telnet. This parameter can also be used to Disable telnet management.
- **Telnet Port:** The default port number for Telnet applications is 23. However, you can use this field if you want to change the Telnet port for security reasons (but your Telnet application also must support the new port number you select).
- **Login Idle Timeout (seconds):** Enter the number of seconds the system will wait for a login attempt. The AP-600 terminates the session when it times out. The range is 1 to 300 seconds; the default is 30 seconds.
- **Session Idle Timeout (seconds):** Enter the number of seconds the system will wait during a session while there is no activity. The AP-600 will terminate the session on timeout. The range is 1 to 36000 seconds; the default is 900 seconds.

Serial Configuration Settings

The serial port interface on the AP-600 is enabled at all times. See [Setting IP Address using Serial Port and Normal CLI](#) for information on how to access the CLI interface via the serial port. You can configure and view following parameters:

- **Baud Rate:** Select the serial port speed (bits per second). Choose between 2400, 4800, 9600, 19200, 38400, or 57600; the default Baud Rate is 9600.
- **Flow Control:** Select either **None** (default) or **Xon/Xoff** (software controlled) data flow control.

⇒ NOTE

To avoid potential problems when communicating with the AP-600 through the serial port, Proxim recommends that you leave the Flow Control setting at None (the default value).

- **Serial Data Bits:** This is a read-only field and displays the number of data bits used in serial communication (8 data bits by default).
- **Serial Parity:** This is a read-only field and displays the number of parity bits used in serial communication (no parity bits by default).
- **Serial Stop Bits:** This is a read-only field that displays the number of stop bits used in serial communication (1 stop bit by default).

⇒ NOTE

The serial port bit configuration is commonly referred to as **8N1**.

Filtering

The Access Point's Packet Filtering features help control the amount of traffic exchanged between the wired and wireless networks. There are four sub-categories under the Filtering heading.

- [Ethernet Protocol](#)
- [Static MAC](#)
- [Advanced](#)
- [TCP/UDP Port](#)

Ethernet Protocol

The Ethernet Protocol Filter blocks or forwards packets based on the Ethernet protocols they support.

Follow these steps to configure the Ethernet Protocol Filter:

1. Select the interfaces or interfaces that will implement the filter from the **Ethernet Protocol Filtering** drop-down menu.
 - **Ethernet:** Packets are examined at the Ethernet interface
 - **Wireless:** Packets are examined at the Wireless interface
 - **All Interfaces:** Packets are examined at both interfaces
 - **Disabled:** The filter is not used

Advanced Configuration

2. Select the **Filter Operation Type**.
 - If set to **Passthru**, only the enabled Ethernet Protocols listed in the Filter Table will pass through the bridge.
 - If set to **Block**, the bridge will block enabled Ethernet Protocols listed in the Filter Table.
3. Configure the **Ethernet Protocol Filter Table**. This table is pre-populated with existing Ethernet Protocol Filters, however, you may enter additional filters by specifying the appropriate parameters.
 - To add an entry, click **Add**, and then specify the **Protocol Number** and a **Protocol Name**.
 - **Protocol Number:** Enter the protocol number. See <http://www.iana.org/assignments/ethernet-numbers> for a list of protocol numbers.
 - **Protocol Name:** Enter related information, typically the protocol name.
 - To edit or delete an entry, click **Edit** and change the information, or select **Enable**, **Disable**, or **Delete** from the **Status** drop-down menu.
 - An entry's status must be enabled in order for the protocol to be subject to the filter.

Static MAC

The Static MAC Address filter optimizes the performance of a wireless (and wired) network. When this feature is properly configured, the AP-600 can block traffic between wired devices and wireless devices based on MAC address. For example, you can set up a Static MAC filter to prevent wireless clients from communicating with a specific server on the Ethernet network. You can also use this filter to block unnecessary multicast packets from being forwarded to the wireless network.

NOTE

The Static MAC Filter is an advanced feature. You may find it easier to control wireless traffic via other filtering options, such as Ethernet Protocol Filtering.

Each static MAC entry contains the following fields:

- **Wired MAC Address**
- **Wired Mask**
- **Wireless MAC Address**
- **Wireless Mask**
- **Comment:** This field is optional.

Each MAC Address or Mask is comprised of 12 hexadecimal digits (0-9, A-F) that correspond to a 48-bit identifier. (Each hexadecimal digit represents 4 bits (0 or 1).)

Taken together, a MAC Address/Mask pair specifies an address or a range of MAC addresses that the AP-600 will look for when examining packets. The AP-600 uses Boolean logic to perform an "AND" operation between the MAC Address and the Mask at the bit level. However, for most users, you do not need to think in terms of bits. It should be sufficient to create a filter using only the hexadecimal digits 0 and F in the Mask (where 0 is any value and F is the value specified in the MAC address). A Mask of 00:00:00:00:00:00 corresponds to all MAC addresses, and a Mask of FF:FF:FF:FF:FF:FF applies only to the specified MAC Address.

For example, if the MAC Address is 00:20:A6:12:54:C3 and the Mask is FF:FF:FF:00:00:00, the AP-600 will examine the source and destination addresses of each packet looking for any MAC address starting with 00:20:A6. If the Mask is FF:FF:FF:FF:FF:FF, the AP-600 will only look for the specific MAC address (in this case, 00:20:A6:12:54:C3).

When creating a filter, you can configure the Wired parameters only, the Wireless parameters only, or both sets of parameters. Which parameters to configure depends upon the traffic that you want block:

- To prevent all traffic from a specific wired MAC address from being forwarded to the wireless network, configure only the Wired MAC Address and Wired Mask (leave the Wireless MAC Address and Wireless Mask set to all zeros).
- To prevent all traffic from a specific wireless MAC address from being forwarded to the wired network, configure only the Wireless MAC address and Wireless Mask (leave the Wired MAC Address and Wired Mask set to all zeros).
- To block traffic between a specific wired MAC address and a specific wireless MAC address, configure all four parameters.

To create an entry, click **Add** and enter the appropriate MAC addresses and Masks to setup a filter. The entry is enabled automatically when saved. To edit an entry, click **Edit**. To disable or remove an entry, click **Edit** and change the **Status** field from **Enable** to **Disable** or **Delete**.

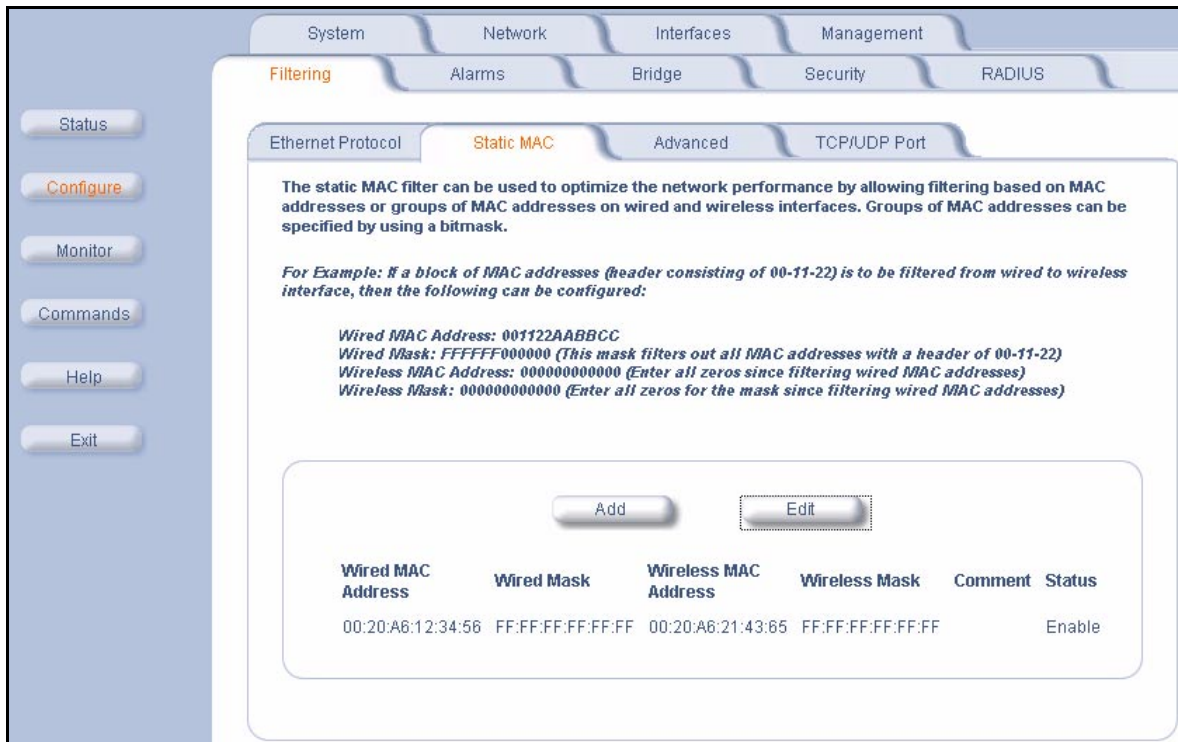

Figure 4-12 Static MAC Configuration Screen

Static MAC Filter Examples

Consider a network that contains a wired server and three wireless clients. The MAC address for each unit is as follows:

- Wired Server: 00:40:F4:1C:DB:6A
- Wireless Client 1: 00:02:2D:51:94:E4
- Wireless Client 2: 00:02:2D:51:32:12
- Wireless Client 3: 00:20:A6:12:4E:38

Prevent Two Specific Devices from Communicating

Configure the following settings to prevent the Wired Server and Wireless Client 1 from communicating:

- **Wired MAC Address:** 00:40:F4:1C:DB:6A
- **Wired Mask:** FF:FF:FF:FF:FF:FF
- **Wireless MAC Address:** 00:02:2D:51:94:E4
- **Wireless Mask:** FF:FF:FF:FF:FF:FF

Result: Traffic between the Wired Server and Wireless Client 1 is blocked. Wireless Clients 2 and 3 can still communicate with the Wired Server.

Advanced Configuration

Prevent Multiple Wireless Devices From Communicating With a Single Wired Device

Configure the following settings to prevent Wireless Clients 1 and 2 from communicating with the Wired Server.

- **Wired MAC Address:** 00:40:F4:1C:DB:6A
- **Wired Mask:** FF:FF:FF:FF:FF:FF
- **Wireless MAC Address:** 00:02:2D:51:94:E4
- **Wireless Mask:** FF:FF:FF:00:00:00

Result: When a logical “AND” is performed on the Wireless MAC Address and Wireless Mask, the result corresponds to any MAC address beginning with the 00:20:2D prefix. Since Wireless Client 1 and Wireless Client 2 share the same prefix (00:02:2D), traffic between the Wired Server and Wireless Clients 1 and 2 is blocked. Wireless Client 3 can still communicate with the Wired Server since it has a different prefix (00:20:A6).

Prevent All Wireless Devices From Communicating With a Single Wired Device

Configure the following settings to prevent all three Wireless Clients from communicating with Wired Server 1.

- **Wired MAC Address:** 00:40:F4:1C:DB:6A
- **Wired Mask:** FF:FF:FF:FF:FF:FF
- **Wireless MAC Address:** 00:00:00:00:00:00
- **Wireless Mask:** 00:00:00:00:00:00

Result: The Access Point blocks all traffic between Wired Server 1 and all wireless clients.

Prevent A Wireless Device From Communicating With the Wired Network

Configure the following settings to prevent Wireless Client 3 from communicating with any device on the Ethernet.

- **Wired MAC Address:** 00:00:00:00:00:00
- **Wired Mask:** 00:00:00:00:00:00
- **Wireless MAC Address:** 00:20:A6:12:4E:38
- **Wireless Mask:** FF:FF:FF:FF:FF:FF

Result: The Access Point blocks all traffic between Wireless Client 3 and the Ethernet network.

Prevent Messages Destined for a Specific Multicast Group from Being Forwarded to the Wireless LAN

If there are devices on your Ethernet network that use multicast packets to communicate and these packets are not required by your wireless clients, you can set up a Static MAC filter to preserve wireless bandwidth. For example, if routers on your network use a specific multicast address (such as 01:00:5E:00:32:4B) to exchange information, you can set up a filter to prevent these multicast packets from being forwarded to the wireless network:

- **Wired MAC Address:** 01:00:5E:00:32:4B
- **Wired Mask:** FF:FF:FF:FF:FF:FF
- **Wireless MAC Address:** 00:00:00:00:00:00
- **Wireless Mask:** 00:00:00:00:00:00

Result: The Access Point does not forward any packets that have a destination address of 01:00:5E:00:32:4B to the wireless network.

Advanced

You can configure the following advanced filtering options:

- **Enable Proxy ARP:** Place a check mark in the box provided to allow the Access Point to respond to Address Resolution Protocol (ARP) requests for wireless clients. When enabled, the AP-600 answers ARP requests for wireless stations without actually forwarding them to the wireless network. If disabled, the Access Point will bridge ARP requests for wireless clients to the wireless LAN.

Advanced Configuration

- **Enable IP/ARP Filtering:** Place a check mark in the box provided to allow IP/ARP filtering based on the IP/ARP Filtering Address and IP Mask. Leave the box unchecked to prevent filtering. If enabled, you should also configure the IP/ARP Filtering Address and IP/ARP IP Mask.
 - **IP/ARP Filtering Address:** Enter the Network filtering IP Address.
 - **IP/ARP IP Mask:** Enter the Network Mask IP Address.

The following protocols are listed in the Advanced Filter Table:

- **Deny IPX RIP**
- **Deny IPX SAP**
- **Deny IPX LSP**
- **Deny IP Broadcasts**
- **Deny IP Multicasts**

The AP-600 can filter these protocols in the wireless-to-Ethernet direction, the Ethernet-to-wireless direction, or in both directions. Click **Edit** and use the **Status** field to Enable or Disable the filter.

TCP/UDP Port

Port-based filtering enables you to control wireless user access to network services by selectively blocking TCP/UDP protocols through the AP-600. A user specifies a Protocol Name, Port Number, Port Type (TCP, UDP, or TCP/UDP), and filtering interfaces (Wireless only, Ethernet only, all interfaces, or no interfaces) in order to block access to services, such as Telnet and FTP, and traffic, such as NETBIOS and HTTP.

For example, an AP-600 with the following configuration would discard frames received on its Wireless radio with a UDP destination port number of 137, effectively blocking NETBIOS Name Service packets.

Protocol Type (TCP/UDP)	Destination Port Number	Protocol Name	Interface	Status (Enable/Disable)
UDP	137	NETBIOS Name Service	Wireless	Enable

Adding TCP/UDP Port Filters

1. Place a check mark in the box labeled **Enable TCP/UDP Port Filtering**.
2. Click **Add** under the **TCP/UDP Port Filter Table** heading.

The screenshot shows the 'Filtering' section of the web interface. A dialog box titled 'TCP/UDP Port Filter Table - Add Entries' is open. It contains the following fields and values:

- Protocol Name: (empty)
- Port Number (0-65535): 1732
- Port Type: TCP/UDP
- Interface: All Interfaces

Buttons for 'OK' and 'Cancel' are visible at the bottom of the dialog.

Figure 4-13 Adding a New TCP/UDP Port Filter Entry

3. In the **TCP/UDP Port Filter Table**, enter the Protocol Names to filter.
4. Set the destination Port Number (a value between 0 and 65535) to filter. See the IANA Web site at <http://www.iana.org/assignments/port-numbers> for a list of assigned port numbers and their descriptions.

Advanced Configuration

5. Set the Port Type for the protocol: **TCP**, **UDP**, or both (**TCP/UDP**).
6. Set the **Interface** to filter:
 - Wireless
 - Ethernet
 - All interfaces
 - No interfaces
7. Click **OK**.



NOTE

Filters are enabled by default. Packets that the AP-600 receives on the specified interface(s) with the specified TCP/UDP destination port, are discarded.

Editing TCP/UDP Port Filters

1. Click **Edit** under the **TCP/UDP Port Filter Table** heading.
2. Make any changes to the Protocol Name or Port Number for a specific entry, if necessary.
3. In the row that defines the port, set the **Status** to **Enable**, **Disable**, or **Delete**, as appropriate.
4. Select **OK**.

Alarms

This category has three sub-categories.

- [Groups](#)
- [Alarm Host Table](#)
- [Syslog](#)

Groups

There are seven alarm groups that can be enabled or disabled:

- **Enable Configuration Alarms**
- **Enable Security Alarms**
- **Enable Wireless Alarms**
- **Enable Operational Alarms**
- **Enable Flash Memory Alarms**
- **Enable TFTP Alarms**
- **Enable Image Alarms**

Place a check mark in the box provided to enable a specific group. Remove the check mark from the box to disable the alarms.

These alarm groups correspond to System Alarms that are displayed in the HTTP interface's [System Status](#) screen and to traps that are sent by the AP-600 to the SNMP managers specified in the [Alarm Host Table](#).

See [System Alarms \(Traps\)](#) for the list of alarms contained in each group.

Alarm Host Table

To add an entry and enable the AP-600 to send SNMP trap messages to a Trap Host, click **Add**, and then specify the IP Address and Password for the Trap Host.

- **IP Address:** Enter the Trap Host IP Address.
- **Password:** Enter the password in the **Password** field and the **Confirm** field.
- **Comment:** Enter an optional comment, such as the alarm (trap) host station name.

To edit or delete an entry, click **Edit**. Edit the information, or select **Enable**, **Disable**, or **Delete** from the **Status** drop-down menu.

Syslog

The Syslog messaging system enables the AP-600 to transmit event messages to a central server for monitoring and troubleshooting. The access point logs “Session Start (Log-in)” and “Session Stop (Log-out)” events for each wireless client as an alternative to RADIUS accounting.

See RFC 3164 at <http://www.rfc-editor.org/> for more information on the Syslog standard.

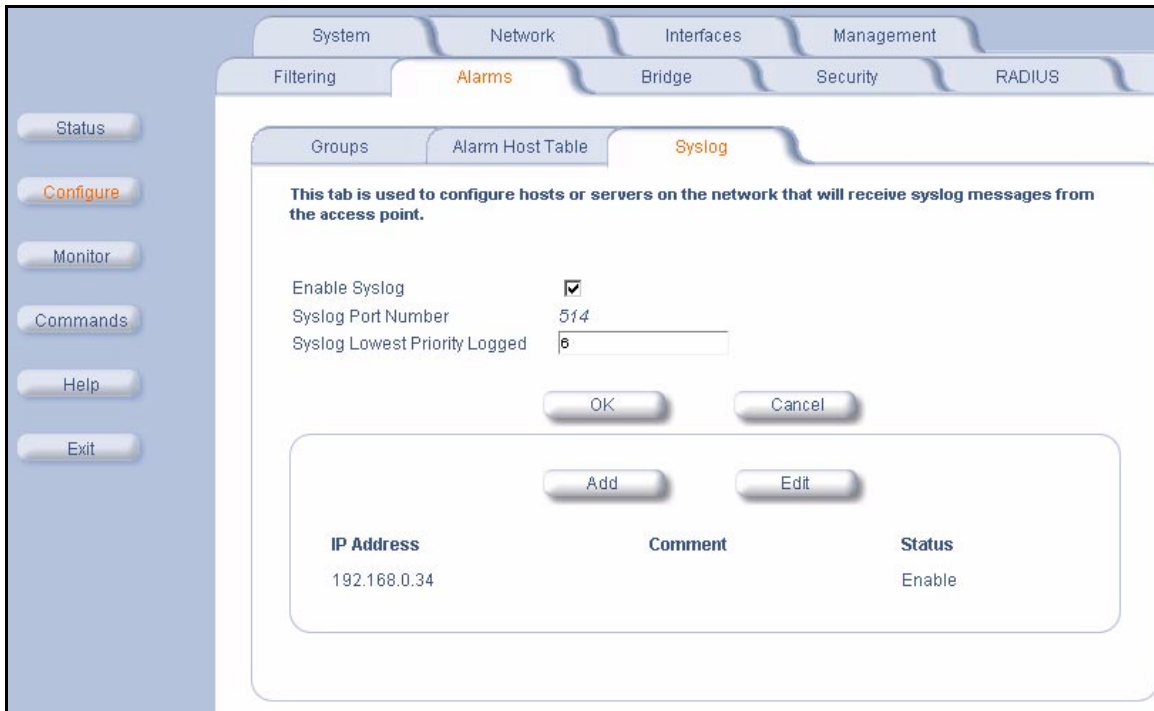

Figure 4-14 Syslog Configuration Screen

Setting Syslog Event Notifications

Syslog Events are logged according to the level of detail specified by the administrator. Logging only urgent system messages will create a far smaller, more easily read log then a log of every event the system encounters. Determine which events to log by selecting a priority defined by the following scale:

Event	Priority	Description
LOG_EMERG	0	system is unusable
LOG_ALERT	1	action must be taken immediately
LOG_CRIT	2	critical conditions
LOG_ERR	3	error conditions
LOG_WARNING	4	warning conditions
LOG_NOTICE	5	normal but significant condition
LOG_INFO	6	informational
LOG_DEBUG	7	debug-level messages

Configuring Syslog Event Notifications

You can configure the following Syslog settings from the HTTP interface:

- **Enable Syslog:** Place a check mark in the box provided to enable system logging.
- **Syslog Port Number:** This field is read-only and displays the port number (514) assigned for system logging.

Advanced Configuration

- **Syslog Lowest Priority Logged:** The AP-600 will send event messages to the Syslog server that correspond to the selected priority and above. For example, if set to 6, the AP-600 will transmit event messages labeled priority 0 to 6 to the Syslog server(s).
- **Syslog Host Table:** This table specifies the IP addresses of a network servers that the AP-600 will send Syslog messages to. Click **Add** to create a new entry. Click **Edit** to change an existing entry. Each entry contains the following field:
 - **IP Address:** Enter the IP Address for the management host.
 - **Comment:** Enter an optional comment such as the host name.
 - **Status:** The entry is enabled automatically when saved (so the Status field is only visible when editing an entry). You can also disable or delete entries by changing this field's value.

Bridge

The AP-600 is a bridge between your wired and wireless networking devices. As a bridge, the functions performed by the AP-600 include:

- MAC address learning
- Forward and filtering decision making
- Spanning Tree protocol used for loop avoidance

Once the AP-600 is connected to your network, it learns which devices are connected to it and records their MAC addresses in the Learn Table. The table can hold up to 10,000 entries. To view the Learn Table, click on the **Monitor** button in the web interface and select the [Learn Table](#) tab.

The **Bridge** tab has four sub-categories.

- [Spanning Tree](#)
- [Storm Threshold](#)
- [Intra BSS](#)
- [Packet Forwarding](#)

Spanning Tree

A Spanning Tree is used to avoid redundant communication loops in networks with multiple bridging devices. Bridges do not have any inherent mechanism to avoid loops, because having redundant systems is a necessity in certain networks. However, redundant systems can cause Broadcast Storms, multiple frame copies, and MAC address table instability problems.

Complex network structures can create multiple loops within a network. The Spanning Tree configuration blocks certain ports on AP-600 devices to control the path of communication within the network, avoiding loops and following a spanning tree structure.

For more information on Spanning Tree protocol, please see Section 8.0 of the IEEE 802.1d standard. The Spanning Tree configuration options are advanced settings. Proxim recommends that you leave these parameters at their default values unless you are familiar with the Spanning Tree protocol.

Storm Threshold

Storm Threshold is an advanced Bridge setup option that you can use to protect the network against data overload by:

- Specifying a maximum number of frames per second as received from a single network device (identified by its MAC address).
- Specifying an absolute maximum number of messages per port.

The Storm Threshold parameters allow you to specify a set of thresholds for each port of the AP-600, identifying separate values for the number of broadcast messages/second and Multicast messages/second.

When the number of frames for a port or identified station exceeds the maximum value per second, the AP-600 will ignore all subsequent messages issued by the particular network device, or ignore all messages of that type.

- **Address Threshold:** Enter the maximum allowed number of packets per second.
- **Ethernet Threshold:** Enter the maximum allowed number of packets per second.
- **Wireless Threshold:** Enter the maximum allowed number of packets per second.

Intra BSS

The wireless clients (or *subscribers*) that associate with a certain AP-600 form the Basic Service Set (BSS) of a network infrastructure. By default, wireless subscribers in the same BSS can communicate with each other. However, some administrators (such as wireless public spaces) may wish to block traffic between wireless subscribers that are associated with the same AP-600 to prevent unauthorized communication and to conserve bandwidth. This feature enables you to prevent wireless subscribers within a BSS from exchanging traffic.

Although this feature is generally enabled in public access environments, Enterprise LAN administrators use it to conserve wireless bandwidth by limiting communication between wireless clients. For example, this feature prevents peer-to-peer file sharing or gaming over the wireless network.

To block Intra BSS traffic, set **Intra BSS Traffic Operation** to **Block**.

To allow Intra BSS traffic, set **Intra BSS Traffic Operation** to **Passthru**.

Packet Forwarding

The Packet Forwarding feature enables you to redirect traffic generated by wireless clients that are all associated to the same AP-600 to a single MAC address. This filters wireless traffic without burdening the AP-600 and provides additional security by limiting potential destinations or by routing the traffic directly to a firewall. You can redirect to a specific port (Ethernet or WDS) or allow the bridge's learning process (and the forwarding table entry for the selected MAC address) to determine the optimal port.



NOTE

The gateway to which traffic will be redirected should be node on the Ethernet network. It should not be a wireless client.

Configuring Interfaces for Packet Forwarding

Configure your AP-600 to forward packets by specifying interface port(s) to which packets are redirected and a destination MAC address.

1. Within the **Packet Forwarding Configuration** screen, check the box labeled **Enable Packet Forwarding**.
2. Specify a destination **Packet Forwarding MAC Address**. The AP-600 will redirect all unicast, multicast, and broadcast packets received from wireless clients to the address you specify.
3. Select a **Packet Forwarding Interface Port** from the drop-down menu. You can redirect traffic to:
 - Ethernet
 - A WDS connection (see [Wireless Distribution System \(WDS\)](#) for details)
 - Any (traffic is redirected to a port based on the bridge learning process)
4. Click **OK** to save your changes.

Security

The AP-600 provides three security features to protect your network from unauthorized individuals.

- [MAC Access](#)
- [WEP Encryption](#)
- [802.1x](#)

The HTTP interface provides a configuration screen for each of these features.

Advanced Configuration

MAC Access

The MAC Access tab allows you to build a list of stations, identified by their MAC addresses, authorized to access the network through the AP-600. The list is stored inside each AP-600 within your network. Note that you must reboot the AP-600 for any changes to the MAC Access Control Table to take effect.

- **Enable MAC Access Control:** Check this box to enable the Control Table.
- **Operation Type:** Choose between **Passthru** and **Block**. This determines how the stations identified in the MAC Access Control Table are filtered.
 - If set to **Passthru**, only the addresses listed in the Control Table will pass through the bridge.
 - If set to **Block**, the bridge will block traffic to or from the addresses listed in the Control Table.
- **MAC Access Control Table:** Click **Add** to create a new entry. Click **Edit** to change an existing entry. Each entry contains the following field:
 - **MAC Address:** Enter the wireless client's MAC address.
 - **Comment:** Enter an optional comment such as the client's name.
- **Status:** The entry is enabled automatically when saved (so the Status field is only visible when editing an entry). You can also disable or delete entries by changing this field's value.

⇒ NOTE

For larger networks that include multiple Access Points, you may prefer to maintain this list on a centralized location using the [MAC Access Control Via RADIUS Authentication](#).

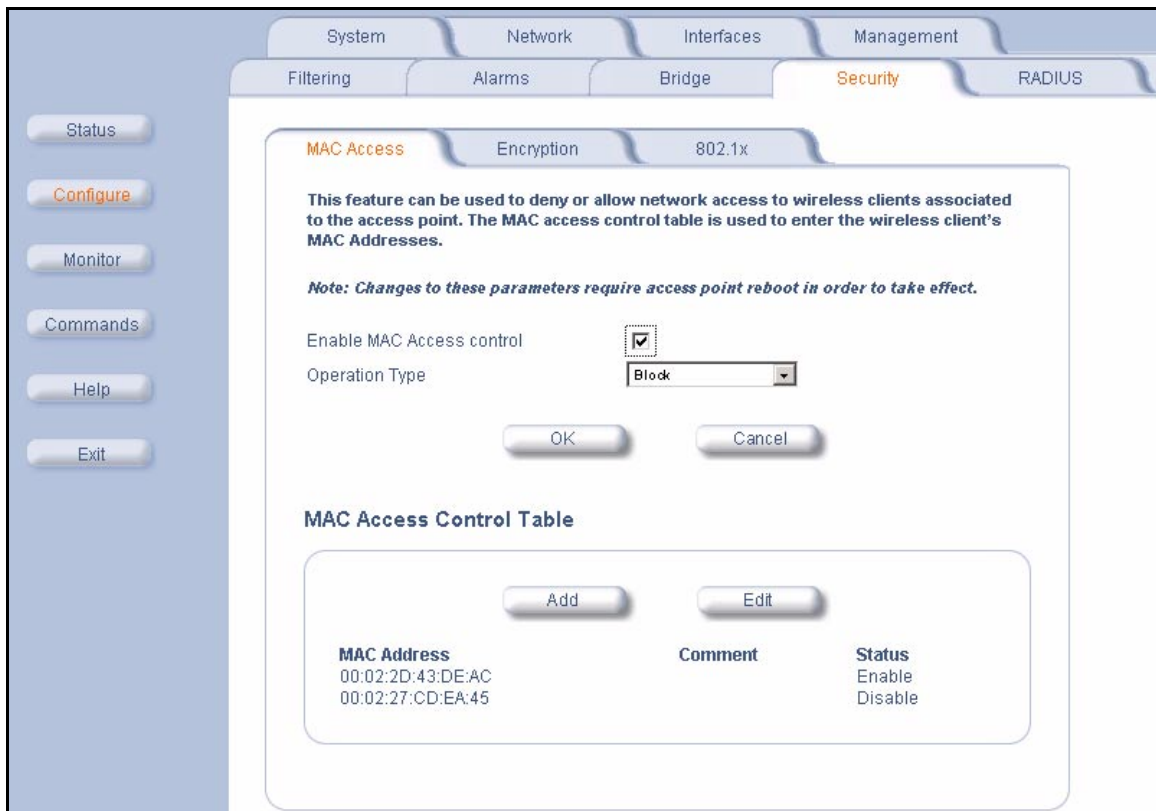

Figure 4-15 MAC Access Configuration Screen

Advanced Configuration

WEP Encryption

The IEEE 802.11 standards specify an optional encryption feature, known as Wired Equivalent Privacy or WEP, that is designed to provide a wireless LAN with a security level equal to what is found on a wired Ethernet network. WEP encrypts the data portion of each packet exchanged on an 802.11 network using an Encryption Key (also known as a WEP Key).

When Encryption is enabled, two 802.11 devices must have the same Encryption Keys and both devices must be configured to use Encryption in order to communicate. If one device is configured to use Encryption but a second device is not, then the two devices will not communicate, even if both devices have the same Encryption Keys.

- The AP-600b supports 64-bit and 128-bit encryption:
 - For 64-bit encryption, an encryption key is 10 hexadecimal characters (0-9 and A-F) or 5 ASCII characters (see [ASCII Character Chart](#)).
 - For 128-bit encryption, an encryption key is 26 hexadecimal characters or 13 ASCII characters.
- The AP-600a supports 64-bit, 128-bit, and 152-bit encryption:
 - For 64-bit encryption, an encryption key is 10 hexadecimal characters (0-9 and A-F) or 5 ASCII characters (see [ASCII Character Chart](#)).
 - For 128-bit encryption, an encryption key is 26 hexadecimal characters or 13 ASCII characters.
 - For 152-bit encryption, an encryption key is 32 hexadecimal characters or 16 ASCII characters.

⇒ NOTE

64-bit encryption is sometimes referred to as 40-bit encryption; 128-bit encryption is sometimes referred to as 104-bit encryption.

MAC Access Encryption 802.1x

This tab is used to configure encryption (WEP) in the access point. This is used to provide data security for wireless communication between the access point and wireless clients. Encryption settings can be configured for both wireless interfaces.

Note: The access point supports 64, 128, and 152 bit keys depending on the wireless PC card in the device. The following table provides information on how to configure encryption keys using HEX or ASCII values.

	Configuration in Hex	Configuration in ASCII
64 bit encryption key	10 characters (0-F)	5 alphanumeric characters
128 bit encryption key	26 characters (0-F)	13 alphanumeric characters
152 bit encryption key	32 characters (0-F)	16 alphanumeric characters

Warning: Connectivity requires that encryption keys on the access point and the wireless clients be identical.

Note: Changes to these parameters require access point reboot in order to take effect.

Enable Encryption (WEP) for Wireless Interface

Wireless Interface

Encryption Key 1

Encryption Key 2

Encryption Key 3

Encryption Key 4

Deny Non-Encrypted Data

Encrypt Data Transmissions Using

OK Cancel

Figure 4-16 Encryption Configuration

Advanced Configuration

Follow these steps to set up WEP encryption on an AP-600:

1. Place a check mark in the box labeled **Enable Encryption (WEP)**.
2. Enter one to four Encryption Keys in the fields provided. Keep in mind the following:
 - If entering more than one Key, use the same number of characters for each Key. All Keys need to be the same Key Size (64, 128, or 152-bit).
 - You can enter the Encryption Keys in either hexadecimal or ASCII format.
 - You need to configure your wireless clients to use the same Keys in order for the clients and the AP-600 to communicate.
3. Set **Deny Non-Encrypted Data** to **Enable** if you want to prevent clients that do not have WEP enabled or the proper keys configured from communicating with the network.
4. Select the Key that the AP-600 will use to encryption outgoing data from the **Encrypt Data Transmissions Using** drop-down menu. By default, this parameter is set to Key 1.
5. Click **OK**.

802.1x

IEEE 802.1x is a standard that provides a means to authenticate and authorize network devices attached to a LAN port. A port in the context of IEEE 802.1x is a point of attachment to the LAN, either a physical Ethernet connection or a wireless link to an Access Point. 802.1x requires a **RADIUS** server and uses the Extensible Authentication Protocol (EAP) as a standards-based authentication framework, and supports automatic key distribution for enhanced security. The EAP-based authentication framework can easily be upgraded to keep pace with future EAP types.

Popular EAP types include:

- EAPoL (EAP over LAN): Transport protocol used to negotiate the wireless user's secure connection to the network. EAP messages are encapsulated in 802.1x messages.
- EAP-Message Digest 5 (MD5): Username/Password-based authentication; does not support automatic key distribution
- EAP-Transport Layer Security (TLS): Certificate-based authentication (a certificate is required on the server and each client); supports automatic key distribution
- EAP-Tunneled Transport Layer Security (TTLS): Certificate-based authentication (a certificate is required on the server; a client's username/password is tunneled to the server over a secure connection); supports automatic key distribution
- PEAP - Protected EAP with MS-CHAP v2: Secure username/password-based authentication; supports automatic key distribution

Different servers support different EAP types and each EAP type provides different features. Refer to the documentation that came with your RADIUS server to determine which EAP types it supports.



NOTE

The AP-600 supports the following EAP types when 802.1x Security Mode is set to 802.1x: EAP-TLS, PEAP, and EAP-TTLS. When 802.1x Security Mode is set to Mixed, the AP-600 supports the following EAP types: EAP-TLS, PEAP, EAP-TLLS, and EAP-MD5 (MD5 does not support automatic key distribution; therefore, if you choose this method you need to manually configure each client with the network's encryption key).

Authentication Process

There are three main components in the authentication process. The standard refers to them as:

1. supplicant (client PC)
2. authenticator (Access Point)
3. authentication server (RADIUS server)

When using 802.1x Security Mode or Mixed mode (802.1x and WEP), you need to configure your RADIUS server for authentication purposes.

Prior to successful authentication, an unauthenticated client PC cannot send any data traffic through the AP-600 device to other systems on the LAN. The AP-600 inhibits all data traffic from a particular client PC until the client PC is authenticated. Regardless of its authentication status, a client PC can always exchange 802.1x messages in the clear with the AP-600 (the client begins encrypting data after it has been authenticated).

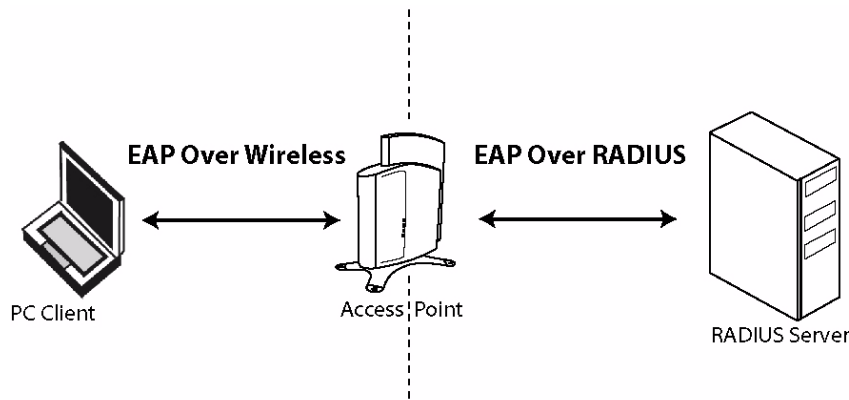

Figure 4-17 RADIUS Authentication Illustrated

The AP-600 acts as a pass-through device to facilitate communications between the client PC and the RADIUS server. The AP-600 and the client exchange 802.1x messages using an EAPOL (EAP Over LAN) protocol. Messages sent from the client station are encapsulated by the AP-600 and transmitted to the RADIUS server using EAP extensions.

Upon receiving a reply EAP packet from the RADIUS, the message is typically forwarded to the client, after translating it back to the EAPOL format. Negotiations take place between the client and the RADIUS server. After the client has been successfully authenticated, the client receives an Encryption Key from the AP-600 (if the EAP type supports automatic key distribution). The client uses this key to encrypt data after it has been authenticated.

For 802.11a clients that communicate with an AP-600a, each client receives its own unique encryption key; this is known as Per User Per Session Encryption Keys. (This feature is only available when using 802.1x mode; it is not available when in Mixed mode or using WEP encryption only).

Configuring Security Settings

The AP-600 offers four security settings:

➤ NOTE

802.1x settings are located under the **802.1x** heading. WEP Encryption settings are located under the **Encryption** heading.

- **No security or encryption**
- **WEP encryption only**
 - See [WEP Encryption](#) for details.
- **802.1x security**
- **Mixed Mode (802.1x and WEP Encryption)**

802.1x Security

Follow these steps to enable 802.1x only:

1. Within the **802.1x Configuration** screen, set **802.1x Security Mode** to **802.1x**.
2. Select an **Encryption Key Length**.
 - The AP-600b supports 64-bit and 128-bit encryption.
 - The AP-600a supports 64-bit and 128-bit encryption.
3. Enter a **Re-keying Interval**.
 - The Re-keying Interval determines how often a client's encryption key is changed and can be set to any value between 60 - 65535 seconds. Rekeying frustrates hacking attempts without taxing system resources. Setting a fairly frequent rekey value (900 seconds=15 minutes) effectively protects against intrusion without disrupting network activities.
4. Click **OK** to save the changes.

5. If you have not already done so, configure the RADIUS authentication settings (see [RADIUS Authentication with 802.1x](#) for details).
6. Reboot the Access Point.

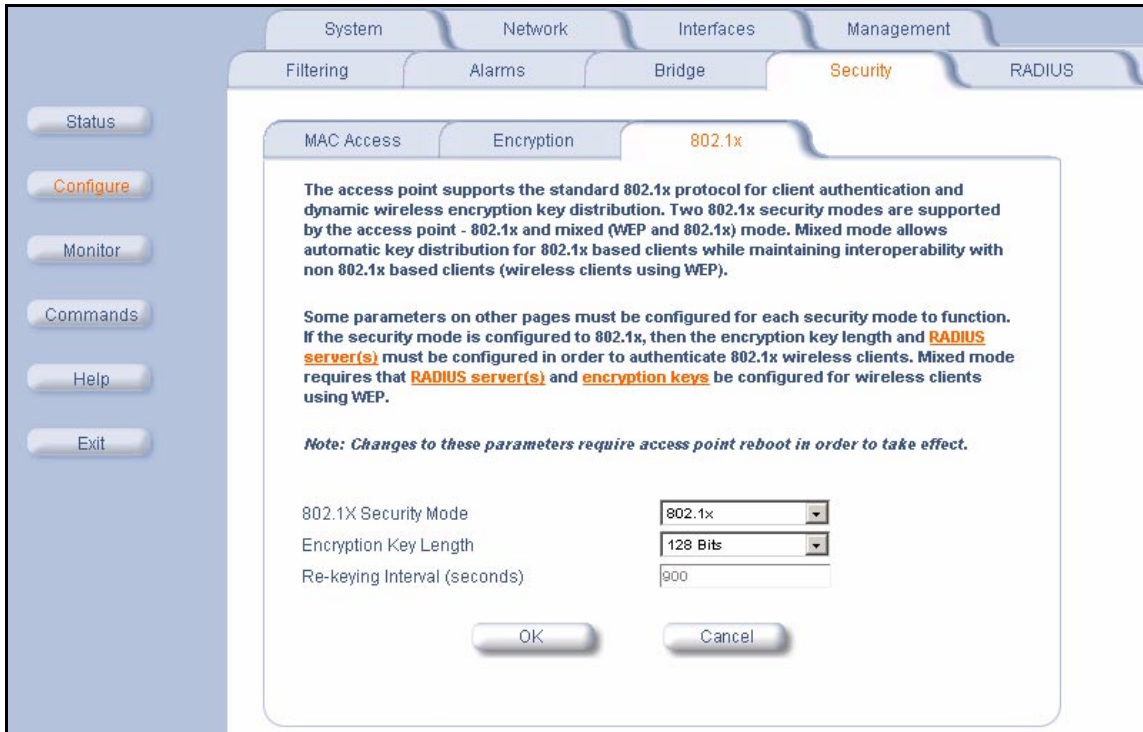

Figure 4-18 802.1x Configuration Screen

Mixed Mode (802.1x and WEP Encryption)

Follow these steps to use both 802.1x and WEP Encryption simultaneously (clients that do not support 802.1x use WEP Encryption for security purposes):

1. Within the **802.1x Configuration** screen, set **802.1x Security Mode** to **Mixed**.
2. Select an **Encryption Key Length**.
 - The AP-600b supports 64-bit and 128-bit encryption.
 - The AP-600a supports 64-bit and 128-bit encryption.
3. Enter a **Re-keying Interval**.
 - The Re-keying Interval determines how often a client's encryption key is changed and can be set to any value between 60 - 65535 seconds. Rekeying frustrates hacking attempts without taxing system resources. Setting a fairly frequent rekey value (900 seconds=15 minutes) effectively protects against intrusion without disrupting network activities.
4. Click **OK** to save the changes.
5. Click the **Encryption** tab.
6. Place a check mark in the box labeled **Enable Encryption (WEP)**.
7. Configure **Encryption Key 1** only (i.e., do not configure Keys 2 through 4). Keep in mind the following:
 - Use the same key size (64/128-bit) that you configured for **Encryption Key Length** on the 802.1x page.
 - For 64-bit encryption, an encryption key is 10 hexadecimal characters (0-9 and A-F) or 5 ASCII characters (see [ASCII Character Chart](#)).
 - For 128-bit encryption, an encryption key is 26 hexadecimal characters or 13 ASCII characters.
 - You can enter the Encryption Keys in either hexadecimal or ASCII format.
 - You need to manually configure your wireless clients that do not support 802.1x to use the same Encryption Key.

Advanced Configuration

8. Set **Deny Non-Encrypted Data** to **Enable** if you want to prevent clients that do not have WEP enabled or the proper keys configured from communicating with the network.
9. Confirm that **Key 1** is selected in the **Encrypt Data Transmissions Using** drop-down menu.
10. Click **OK**.
11. If you have not already done so, configure the RADIUS authentication settings (see [RADIUS Authentication with 802.1x](#) for details).
12. Reboot the Access Point.

802.1x Security and Wireless Distribution Systems (WDS)

Wireless distribution systems (WDS) are configured using specific ports on the AP-600b. To use 802.1x with WDS, you need to set the 802.1x Security Mode to Mixed (WEP and 802.1x) and confirm that the AP-600b units communicating in the WDS share the same encryption key (Key 1). See [Wireless Distribution System \(WDS\)](#) for more information.

NOTE

The AP-600a does not support WDS.

RADIUS

The AP-600 communicates with a network's RADIUS server to provide the following features:

- [MAC Access Control Via RADIUS Authentication](#)
- [RADIUS Authentication with 802.1x](#)
- [RADIUS Accounting](#)

You can configure the AP-600 to communicate with up to four different RADIUS servers:

- Primary Authentication Server
- Back-up Authentication Server
- Primary Accounting Server
- Back-up Accounting Server

NOTE

You must have configured the settings for at least one Authentication server before configuring the settings for an Accounting server.

The back-up servers are optional, but when configured, the AP-600 will communicate with the back-up server if the primary server is off-line. After the AP-600 has switched to the backup server, it will periodically check the status of the primary RADIUS server every five (5) minutes. Once the primary RADIUS server is again online, the AP-600 automatically reverts from the backup RADIUS server back to the primary RADIUS server. All subsequent requests are then sent to the primary RADIUS server.

MAC Access Control Via RADIUS Authentication

If you want to control wireless access to the network and if your network includes a RADIUS Server, you can store the list of MAC addresses on the RADIUS server rather than configure each AP-600 individually. From the RADIUS Authentication tab, you can define the IP Address of the server that contains a central list of MAC Address values that identify the authorized stations that may access the wireless network. You must specify information for at least the primary RADIUS server. The back-up RADIUS server is optional.

NOTE

Contact your RADIUS server manufacturer if you have problems configuring the server or have problems using RADIUS authentication.

Follow these steps to enable RADIUS MAC Access Control:

1. Within the **RADIUS Access Control Configuration** screen, place a check mark in the box labeled **Enable RADIUS MAC Access Control**.
2. Place a check mark in the box labeled **Enable Primary RADIUS Authentication Server**.

Advanced Configuration

3. If you want to configure a back-up RADIUS server, place a check mark in the box labeled **Enable Back-up RADIUS Authentication Server**.
4. Enter the time, in seconds, each client session may be active before being automatically re-authenticated in the **Authorization Lifetime** field. This parameter supports a value between 900 and 43200 sec; the default is 900 sec.
5. Select a **MAC Address Format Type**. This should correspond to the format in which the clients' 12-digit MAC addresses are listed within the RADIUS server. Available options include:
 - **Dash delimited:** dash between each pair of digits: xx-yy-zz-aa-bb-cc
 - **Colon delimited:** colon between each pair of digits: xx:yy:zz:aa:bb:cc)
 - **Single dash delimited:** dash between the sixth and seventh digits: xxyyzz-aabbcc
 - **No delimiters:** No characters or spaces between pairs of hexadecimal digits: xxyyzaabbcc
6. Select a **Server Addressing Format** type (IP Address or Name).
 - If you want to identify RADIUS servers by name, you must configure the AP-600 as a DNS Client. See [DNS Client](#) for details.
7. Enter the server's IP address or name in the field provided.
8. Enter the port number which the AP-600 and the server will use to communicate. By default, RADIUS servers communicate on port 1812.
9. Enter the Shared Secret in the **Shared Secret** and **Confirm Shared Secret** field. This is a password shared by the RADIUS server and the AP-600. The same password must also be configured on the RADIUS server.
10. Enter the maximum time, in seconds, that the AP-600 should wait for the RADIUS server to respond to a request in the **Response Time** field. Range is 1-10 seconds; default is 3 seconds.
11. Enter the maximum number of times an authentication request may be retransmitted in the **Maximum Retransmissions** field. Range is 1-4; default is 3.
12. If you are configuring a back-up server, repeat Steps 6 through 11 for the back-up server.
13. Click **OK** to save your changes.
14. Reboot the AP-600 device for these changes to take effect.

RADIUS Auth **RADIUS Acc**

The RADIUS access control provides MAC based authentication of wireless clients via a standard RADIUS server(s). Primary and backup RADIUS servers can be configured.

Note: In order to enable the RADIUS MAC based authentication feature, at least one RADIUS server must be configured.

Note: Changes to these parameters require access point reboot in order to take effect.

Enable RADIUS MAC Access Control

Enable Primary RADIUS Authentication Server

Enable Backup RADIUS Authentication Server

Authorization Lifetime (seconds)

MAC Address Format Type

RADIUS Authentication Server	Primary	Backup
Server Addressing Format	<input type="text" value="IP Address"/>	<input type="text" value="IP Address"/>
Server Name/IP Address	<input type="text" value="192.168.0.65"/>	<input type="text" value="0.0.0.0"/>
Destination Port	<input type="text" value="1812"/>	<input type="text" value="1812"/>
Shared Secret	<input type="text" value="*****"/>	<input type="text" value="*****"/>
Confirm Shared Secret	<input type="text" value="*****"/>	<input type="text" value="*****"/>
Response Time (seconds)	<input type="text" value="3"/>	<input type="text" value="3"/>
Maximum Retransmissions (1-4)	<input type="text" value="3"/>	<input type="text" value="3"/>

Figure 4-19 RADIUS Access Control Configuration Screen

RADIUS Authentication with 802.1x

You must configure a primary RADIUS Authentication server to use 802.1x security. A back-up server is optional.

NOTE

Problems with RADIUS Server configuration or RADIUS Authentication should be referred to the RADIUS Server developer.

Follow these steps to enable a RADIUS Authentication server for 802.1x security:

1. Within the **802.1x Configuration** screen, configure the 802.1x settings. See [802.1x](#) for details.
2. Click the **RADIUS** tab.
3. Click the **RADIUS Auth** sub-tab.
4. Place a check mark in the box labeled **Enable Primary RADIUS Authentication Server**.
5. If you want to configure a back-up RADIUS server, place a check mark in the box labeled **Enable Back-up RADIUS Authentication Server**.
6. Enter the time, in seconds, each client session may be active before being automatically re-authenticated in the **Authorization Lifetime** field. This parameter supports a value between 900 and 43200 sec; the default is 900 sec.
7. Select a **Server Addressing Format** type (IP Address or Name).
 - If you want to identify RADIUS servers by name, you must configure the AP-600 as a DNS Client. See [DNS Client](#) for details.
8. Enter the server's IP address or name in the field provided.
9. Enter the port number which the AP-600 and the server will use to communicate. By default, RADIUS servers communicate on port 1812.
10. Enter the Shared Secret in the **Shared Secret** and **Confirm Shared Secret** field. This is a password shared by the RADIUS server and the AP-600. The same password must also be configured on the RADIUS server.
11. Enter the maximum time, in seconds, that the AP-600 should wait for the RADIUS server to respond to a request in the **Response Time** field. Range is 1-10 seconds; default is 3 seconds.
12. Enter the maximum number of times an authentication request may be retransmitted in the **Maximum Retransmissions** field. Range is 1-4; default is 3.
13. If you are configuring a back-up server, repeat Steps 7 through 12 for the back-up server.
14. Click **OK** to save your changes.
15. Reboot the AP-600 device for these changes to take effect.

RADIUS Accounting

Using an external RADIUS server, the AP-600 can track and record the length of client sessions on the access point by sending RADIUS accounting messages per RFC2866. When a wireless client is successfully authenticated, RADIUS accounting is initiated by sending an "Accounting Start" request to the RADIUS server. When the wireless client session ends, an "Accounting Stop" request is sent to the RADIUS server.

Session Length

Accounting sessions continue when a client reauthenticates to the same AP-600. Sessions are terminated when:

- A client disassociates.
- A client does not transmit any data to the AP-600 for a fixed amount of time.
- A client is detected on a different interface.

If the client roams from one AP-600 to another, one session is terminated and a new session is begun.

NOTE

This feature requires RADIUS authentication using MAC Access Control or 802.1x. Wireless clients configured in the Access Point's static MAC Access Control list are not tracked.

Advanced Configuration

Configuring RADIUS Accounting

Follow these steps to enable RADIUS accounting on the AP-600:

1. Within the **RADIUS Accounting Configuration** screen, place a check mark in the **Enable RADIUS Accounting** box to turn on this feature.
2. Place a check mark in the box labeled **Enable Primary RADIUS Accounting Server**.
3. If you want to configure a back-up RADIUS server, place a check mark in the box labeled **Enable Back-up RADIUS Accounting Server**.
4. Enter the session timeout interval in minutes within the **Accounting Inactivity Timer** field. An accounting session automatically ends for a client that is idle for the period of time specified. Range is 1-60 minutes; default is 5 minutes.
5. Select a **Server Addressing Format** type (IP Address or Name).
 - If you want to identify RADIUS servers by name, you must configure the Access Point as a DNS Client. See [DNS Client](#) for details.
6. Enter the server's IP address or name in the field provided.
7. Enter the port number which the AP-600 and the server will use to communicate. By default, RADIUS accounting uses port 1813.
8. Enter the Shared Secret in the **Shared Secret** and **Confirm Shared Secret** field. This is a password shared by the RADIUS server and the AP-600. The same password must also be configured on the RADIUS server.
9. Enter the maximum time, in seconds, that the AP-600 should wait for the RADIUS server to respond to a request in the **Response Time** field. Range is 1-10 seconds; default is 3 seconds.
10. Enter the maximum number of times an authentication request may be retransmitted in the **Maximum Retransmissions** field. Range is 1-4; default is 3.
11. If you are configuring a back-up server, repeat Steps 5 through 10 for the back-up server.
12. Click **OK** to save your changes.
13. Reboot the AP-600 device for these changes to take effect.

RADIUS Auth
RADIUS Acc

The RADIUS Accounting provides generation of RADIUS accounting Start and Stop messages by the RADIUS client in AP-2000 and sent to one of the RADIUS servers configured (and enabled) in the AP-2000 device. Primary and backup RADIUS Accounting servers can be configured.

Note: RADIUS Accounting shall be done only for wireless clients that have been authenticated through MAC based RADIUS authentication or 802.1x authentication.

Note: Changes to these parameters require access point reboot in order to take effect.

Enable RADIUS Accounting

Enable Primary RADIUS Accounting Server

Enable Backup RADIUS Accounting Server

Accounting Inactivity Timer (minutes)

RADIUS Accounting Server	Primary	Backup
Server Addressing Format	Name <input type="text" value="Name"/>	Name <input type="text" value="Name"/>
Server Name/IP Address	<input type="text" value="Server1"/>	<input type="text" value="Server2"/>
Destination Port	<input type="text" value="1813"/>	<input type="text" value="1813"/>
Shared Secret	<input type="password" value="*****"/>	<input type="password" value="*****"/>
Confirm Shared Secret	<input type="password" value="*****"/>	<input type="password" value="*****"/>
Response Time (seconds)	<input type="text" value="3"/>	<input type="text" value="3"/>
Maximum Retransmissions (1-4)	<input type="text" value="3"/>	<input type="text" value="3"/>

Figure 4-20 RADIUS Accounting Server Configuration

Monitor Information

In This Chapter

This chapter describes the statistical information that is reported within the Access Point's HTTP interface.

- [Logging into the HTTP Interface](#)
- [Version](#): Provides version information for the Access Point's system components.
- [ICMP](#): Displays statistics for Internet Control Message Protocol packets sent and received by the AP-600.
- [IP/ARP Table](#): Displays the AP-600's IP Address Resolution table.
- [Learn Table](#): Displays the list of nodes that the AP-600 has learned are on the network.
- [IAPP](#): Provides statistics for the Inter-Access Point Protocol messages sent and received by the AP-600.
- [RADIUS](#): Provides statistics for the configured primary and backup RADIUS server(s).
- [Interfaces](#): Displays the Access Point's interface statistics (Wireless and Ethernet).
- [Link Test \(AP-600b Only\)](#): Evaluates the link with a wireless client.

Logging into the HTTP Interface

Once the AP-600 has a valid IP Address and an Ethernet connection, you may use your web browser to monitor network statistics.

The Command Line Interface (CLI) also provides a method for viewing network statistics using Telnet or a serial connection. This section covers only use of the HTTP interface. For more information about viewing network statistics with the CLI, refer to [Command Line Interface \(CLI\)](#).

Follow these steps to monitor an AP-600's operating statistics using the HTTP interface:

1. Open a Web browser on a network computer.

NOTE

The HTTP interface supports the following Web browser:

- Microsoft Internet Explorer 5.5 or later
 - Netscape 4.x or later
2. If necessary, disable the Internet proxy settings. For Internet Explorer users, follow these steps:
 - Select **Tools > Internet Options...**
 - Click the **Connections** tab.
 - Click **LAN Settings...**
 - If necessary, remove the check mark from the **Use a proxy server** box.
 - Click **OK** twice to save your changes and return to Internet Explorer.
 3. Enter the Access Point's IP address in the browser's **Address** field and press **Enter**.
 - Result: The AP-600 **Enter Network Password** screen appears.
 4. Enter the HTTP password in the **Password** field and click **OK**. Leave the **User Name** field blank. (By default, the HTTP password is "public").
 - Result: The **System Status** screen appears.

Monitor Information

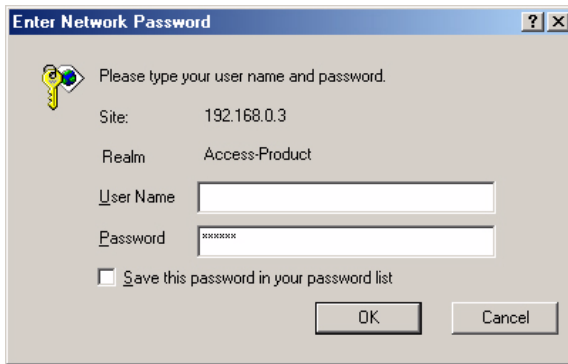

Figure 5-1 Enter Network Password Screen

5. Click the **Monitor** button located on the left-hand side of the screen.

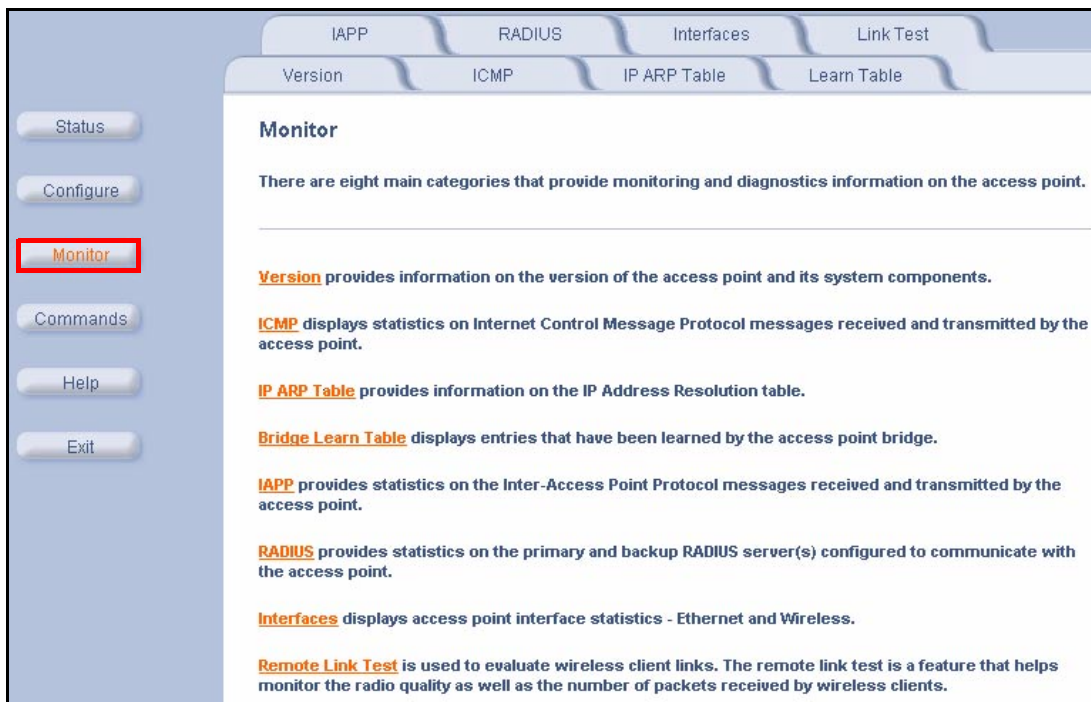



Figure 5-2 Monitor Main Screen

6. Click the tab that corresponds to the statistics you want to review. For example, click **Learn Table** to see the list of nodes that the AP-600 has discovered on the network.
7. If applicable, click the **Refresh**  button to update the statistics.

Monitor Information

Version

From the HTTP interface, click the **Monitor** button and select the **Version** tab. The list displayed provides you with information that may be pertinent when calling Technical Support. With this information, your Technical Support representative can verify compatibility issues and make sure the latest software are loaded. This screen displays the following information for each Access Point component:

- **Serial Number:** The component's serial number, if applicable.
- **Component Name**
- **ID:** The AP-600 identifies a system component based on its ID. Each component has a unique identifier.
- **Variant:** Several variants may exist of the same component (for example, a hardware component may have two variants, one with more memory than the other).
- **Version:** Specifies the component's version or build number. The Software Image version is the most useful information on this screen for the typical end user.

This tab displays version information of the access point system components. This information can be used by Technical Support to diagnose incompatibility issues and to determine if updated software or drivers are required and available.

Serial Number	Name	ID	Variant	Version
Not Applicable	Software Image	89	1	2.1.0
01R706021386	Hardware Inventory	97	1	1.0
Not Applicable	AP- Firmware	842	1	8.42
Not Applicable	BSP-BL Original	111	1	2.0.10
Not Applicable	Wireless MIB	122	1	3.22
Not Applicable	Wireless-PRI Firmware	21	1	4.4
01UT27365294	Wireless-NIC	1	1	4.2

Figure 5-3 Version Information Screen

Monitor Information

ICMP

This tab provides statistical information for both received and transmitted messages directed to the AP-600. Not all ICMP traffic on the network is counted in the ICMP (Internet Control Message Protocol) statistics.

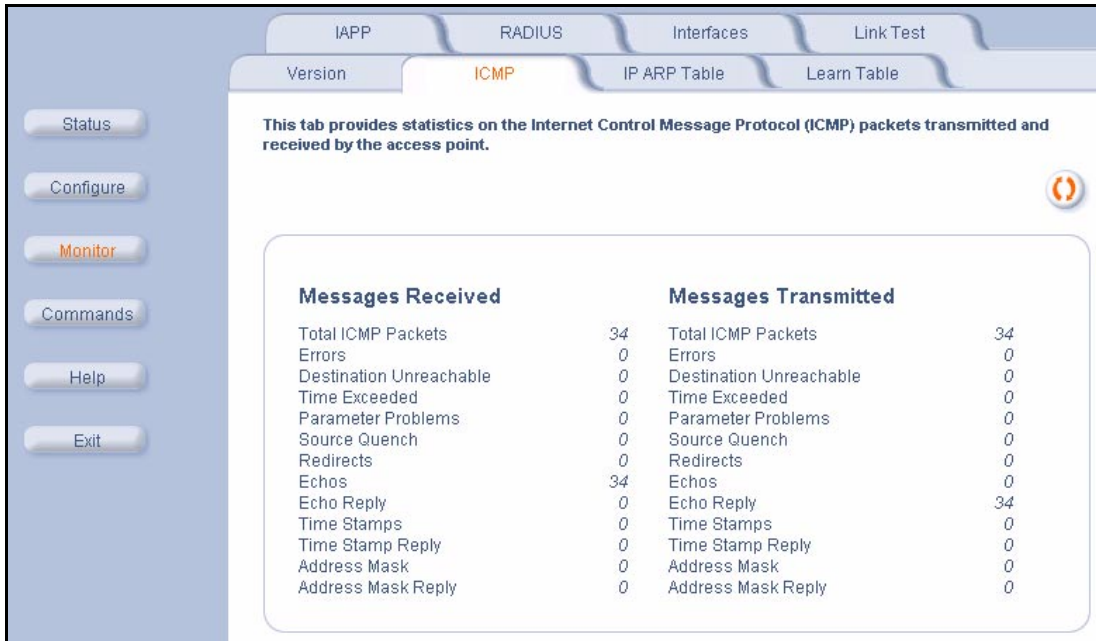

Figure 5-4 ICMP Monitoring Screen

IP/ARP Table

This tab provides information based on the Address Resolution Protocol (ARP), which relates MAC Address and IP Addresses.

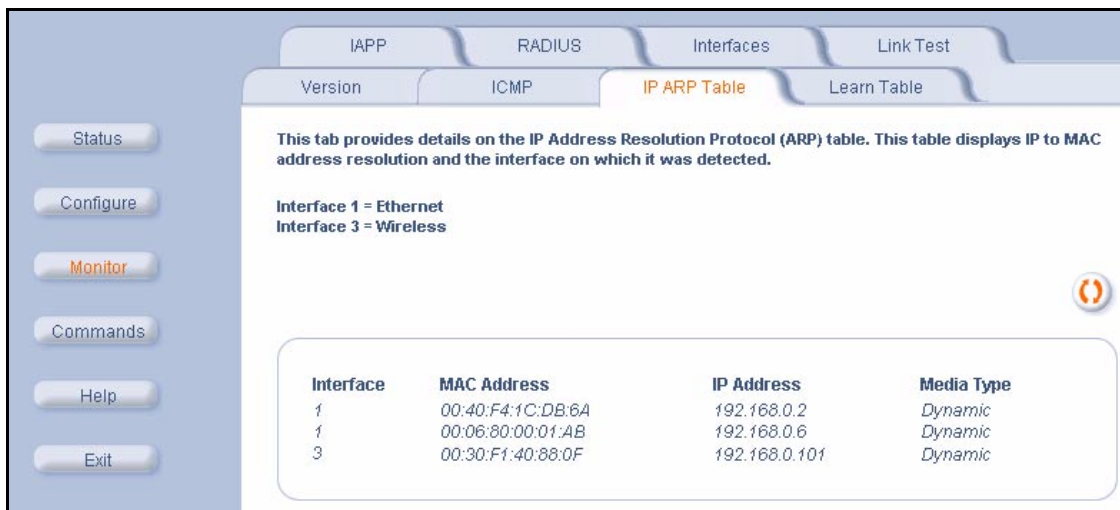

Figure 5-5 IP/ARP Table

Monitor Information

Learn Table

This tab displays information relating to network bridging. It reports the MAC address for each node that the device has learned is on the network and the interface on which the node was detected. There can be up to 10,000 entries in the Learn Table.

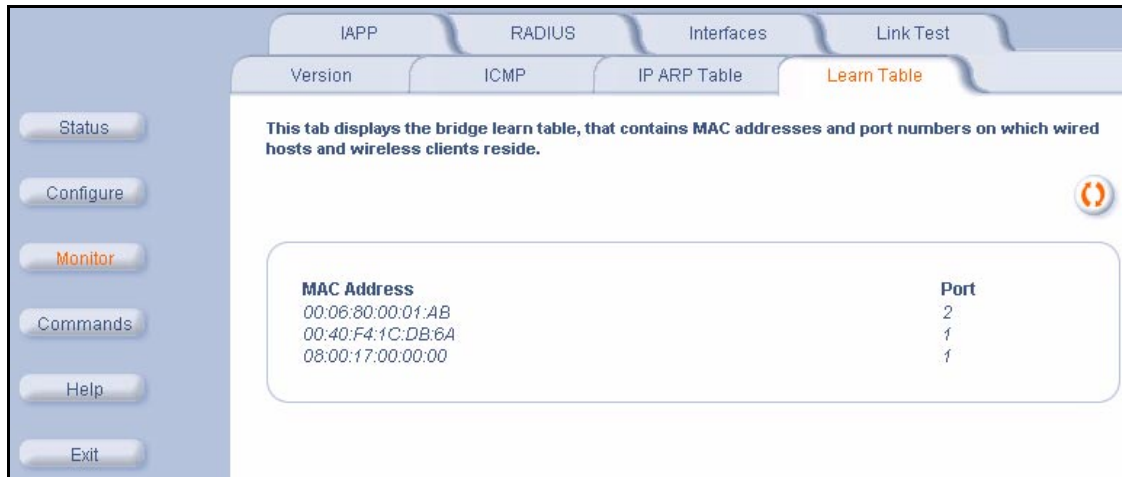

Figure 5-6 Learn Table

IAPP

This tab displays statistics relating to client handovers and communications between ORiNOCO Access Points.

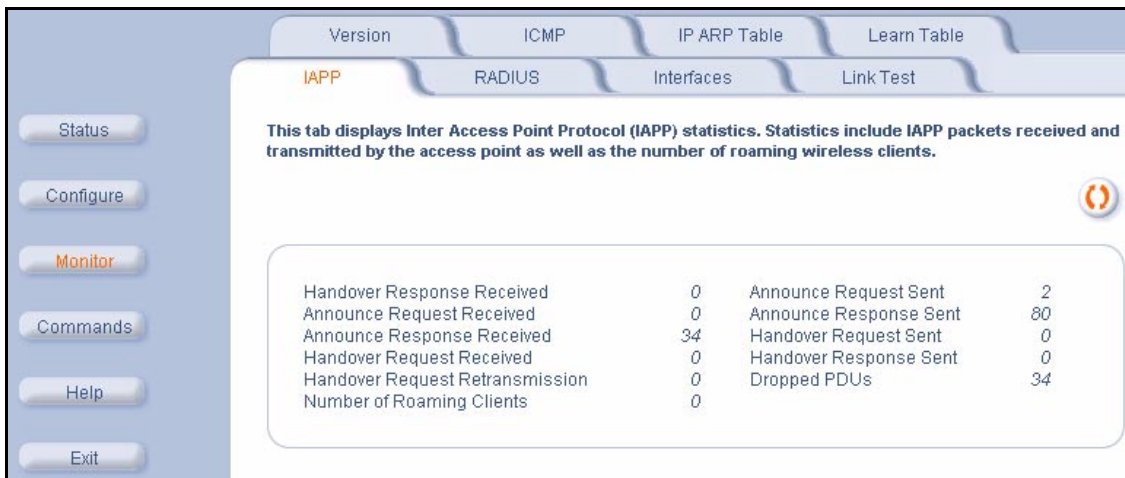

Figure 5-7 IAPP Screen

Monitor Information

RADIUS

This tab provides RADIUS authentication and accounting information for both the Primary and Backup RADIUS servers.

NOTE

RADIUS authentication and accounting must be enabled for this information to be valid.

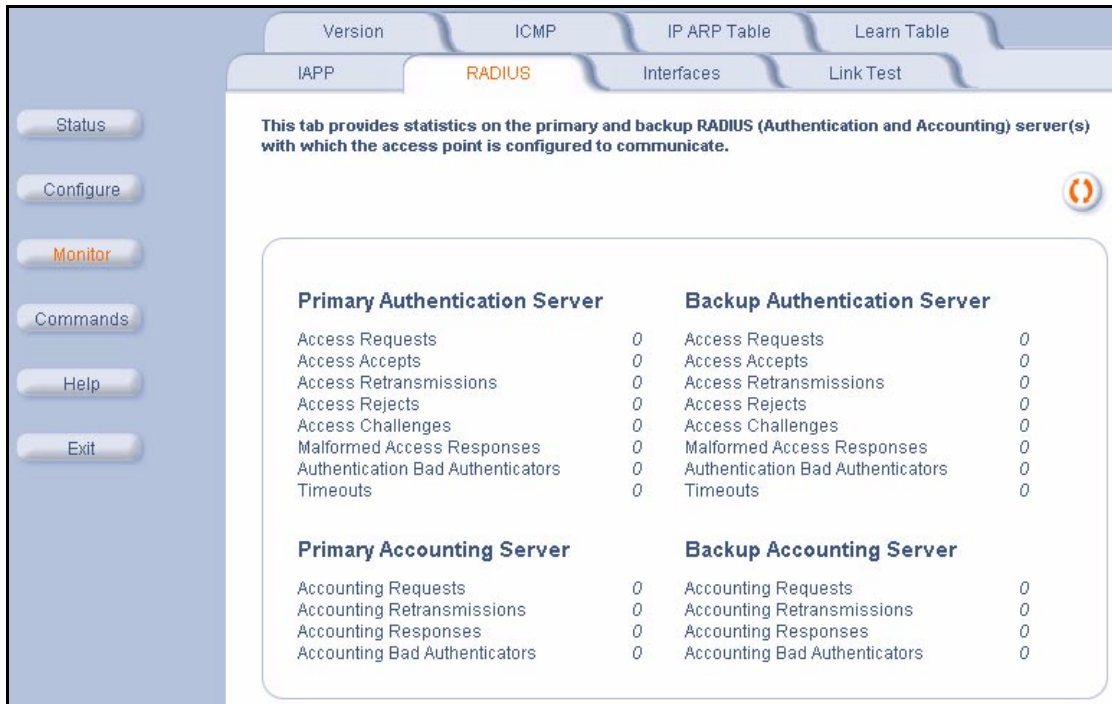

Figure 5-8 RADIUS Monitoring Screen

Monitor Information

Interfaces

This tab displays statistics for the Ethernet and wireless interfaces. The Operational Status can be up, down, or testing.

The screenshot displays two overlapping windows from the Proxim network management interface. The top window shows the 'Ethernet' interface monitoring page, and the bottom window shows the 'Wireless' interface monitoring page. Both windows feature a left-hand navigation menu with buttons for Status, Configure, Monitor, Commands, Help, and Exit. The main content area of each window displays a list of interface statistics.

Ethernet Interface Statistics (ethernet-csmacd):

Type	ethernet-csmacd
Description	
MIB Specific Definition	
Physical Address	
Last Change	
Operational Status	
Admin Status	
Speed	
Maximum Packet Size	
In Octets (bytes)	
In Unicast Packets	
In Non-unicast Packets	
In Discards	
In Errors	
Unknown Protocols	
Out Octets (bytes)	
Out Unicast Packets	
Out Non-unicast Packets	
Out Discards	
Out Errors	
Output Queue Length	
Alignment Error	
FCS Errors	
Single Collision Fram	
Multiple Collision Fram	
SQE Test Errors	
Deferred Transmissio	
Late Collisions	
Excessive Collisions	
Internal MAC Transm	
Carrier Sense Errors	
Frames Too Long	
Internal MAC Receive	

Wireless Interface Statistics (ethernet-csmacd):

Type	ethernet-csmacd
Description	0.0
MIB Specific Definition	wlc1
MAC Address	00:02:2D:2A:67:30
Last Change	140400
Operational Status	Up
Admin Status	Up
Speed	11000000
Maximum Packet Size	1500
In Octets (bytes)	12236
In Unicast Packets	19
In Non-unicast Packets	82
In Discards	0
In Errors	0
Unknown Protocols	0
Out Octets (bytes)	1817820
Out Unicast Packets	1
Out Non-unicast Packets	29582
Out Discards	0
Out Errors	0
Output Queue Length	10
Transmitted Fragment Count	13752
Multicast Transmitted Frame Count	112
Failed Count	0
Retry Count	0
Multiple Retry Count	0
Duplicate Frame Count	0
Successful RTS Count	0
Failed RTS Count	0
Failed ACK Count	0
Received Fragment Count	176
Multicast Received Frame Count	78
FCS Error	0

Figure 5-9 Wireless Interface Monitoring

Monitor Information

Link Test (AP-600b Only)

This tab displays information on the quality of the wireless link to clients and other AP-600b units in the Wireless Distribution System. During a Link Test, the Access Point and the selected device exchange a series of packets to test the strength of the connection. The devices start by exchanging packets at the 11 Mbps/sec rate but fall back to the slower rates if necessary.

NOTE

This feature is not available for the AP-600a. Also, this feature is not available if you are using an ORiNOCO 802.11a/b ComboCard or a non-ORiNOCO client with the AP-600b.

Follow these steps to perform a Link Test:

1. Open the **Remote Link Test** screen.
2. Click **Explore**.

Result: A list of detected stations will appear. If the list does not appear automatically, click **Refresh** .

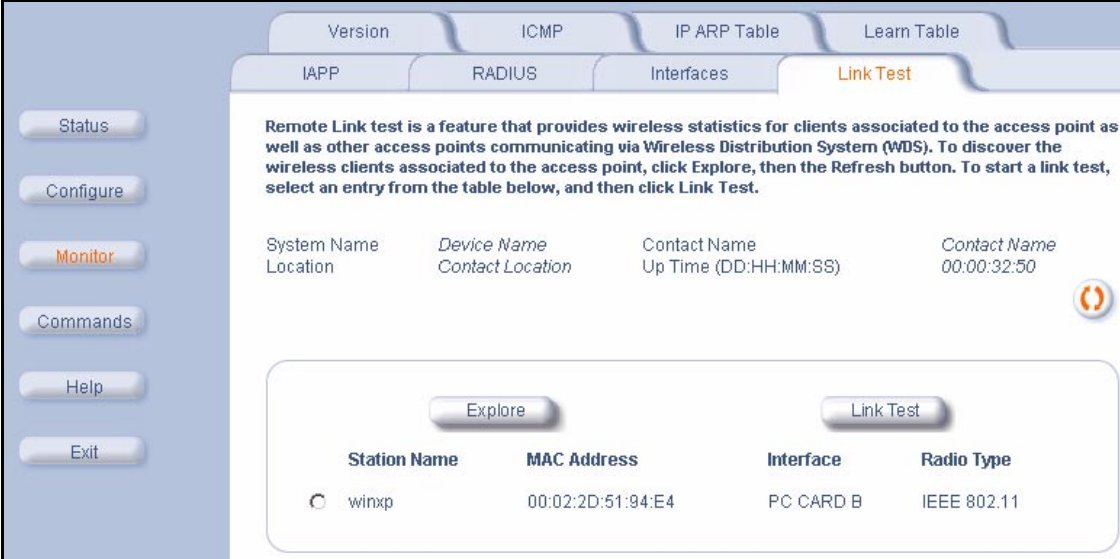

Remote Link test is a feature that provides wireless statistics for clients associated to the access point as well as other access points communicating via Wireless Distribution System (WDS). To discover the wireless clients associated to the access point, click Explore, then the Refresh button. To start a link test, select an entry from the table below, and then click Link Test.

System Name	Device Name	Contact Name	Contact Name
Location	Contact Location	Up Time (DD:HH:MM:SS)	00:00:32:50
winxp	00:02:2D:51:94:E4	PC CARD B	IEEE 802.11

Figure 5-10 Remote Link Test Screen

3. Select a Station from the list by clicking the circle to the left of the Station's entry.
4. Click **Link Test** to start the test.

Result: A new Link Test window opens and displays the following information for the Access Point (referred to as the **Initiator Station**) and the wireless client (referred to as the **Remote Station**):

- **Station Name:** The Access Point's System Name or the client's Windows Networking name.
- **MAC Address**
- **SNR (dB):** The Signal to Noise ratio for the received signal. The displayed value is the running average since the start of the test and is reported in decibels (dB). Higher numbers correspond to a stronger link. The bar graph also displays the relative strength of the link (a green bar indicates a strong link, a yellow bar indicates a fair link, and a red bar indicates a weak link).
- **Signal (dBm):** The strength of the received signal in dBm (decibels referenced to 1 milliwatt). The displayed value is the running average since the start of the test and is reported as a negative number. Higher numbers correspond to a stronger link. For example, -40 dBm corresponds to a stronger signal than -50 dBm. The bar graph also displays the relative strength of the signal (a longer bar represents a stronger signal).

Monitor Information

- **Noise (dBm):** The strength of the noise detected at the receiver reported in dBm (decibels referenced to 1 milliwatt). The displayed value is the running average since the start of the test and is reported as a negative number. Noise can interfere with the received signal so a smaller noise value corresponds to a stronger link. For example, a noise level of -95 dBm is more desirable than a noise level of -89 dBm. The bar graph displays the relative strength of the noise level (a shorter bar represents a weaker noise level and is more desirable than a longer bar).
- **11 Mbps (pkts):** The number of packets received at the 11 Mbits/sec transmit rate since the start of the Link Test. In general, most packets will be received at the 11 Mbits/sec rate if the devices have a strong link.
- **5.5 Mbps (pkts):** The number of packets received at the 5.5 Mbits/sec transmit rate since the start of the Link Test.
- **2 Mbps (pkts):** The number of packets received at the 2 Mbits/sec transmit rate since the start of the Link Test.
- **1 Mbps (pkts):** The number of packets received at the 1 Mbits/sec transmit rate since the start of the Link Test.



NOTE

Click the **Refresh**  button periodically to update the test results. The test screen does not refresh automatically.

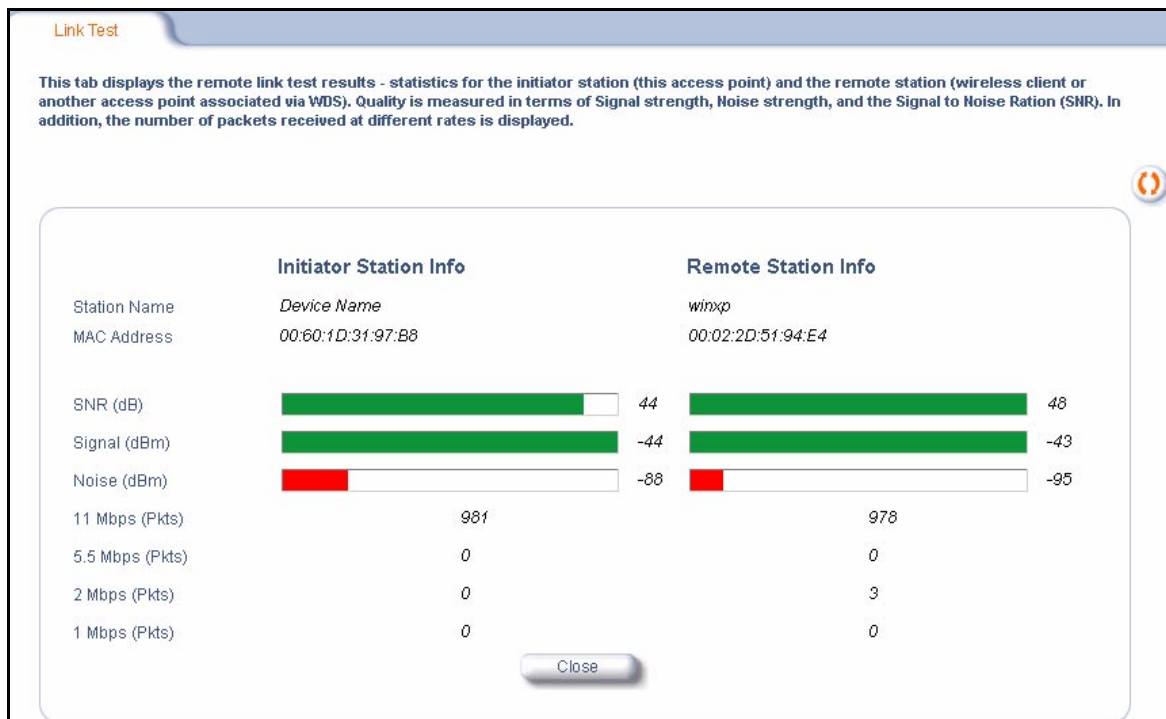

Figure 5-11 SNR Report Screen

5. Click **Close** to end the Link Test.

Commands

In This Chapter

This chapter describes the commands that can be issued from the Access Point's HTTP interface.

- [Logging into the HTTP Interface](#)
- [Download](#): Download files from a TFTP server to the AP-600.
- [Upload](#): Upload configuration files from the AP-600 to a TFTP server.
- [Reboot](#): Reboot the AP-600 in the specified number of seconds.
- [Reset](#): Reset all of the Access Point's configuration settings to factory defaults.
- [Help Link](#): Configure the location where the AP-600 Help files can be found.

Logging into the HTTP Interface

Once the AP-600 has a valid IP Address and an Ethernet connection, you may use your web browser to issue commands.

The Command Line Interface (CLI) also provides a method for issuing commands using Telnet or a serial connection. This section covers only use of the HTTP Interface. For more information about issuing commands with the CLI, refer to [Command Line Interface \(CLI\)](#).

Follow these steps to view the available commands supported by the AP-600's HTTP interface:

1. Open a Web browser on a network computer.

NOTE

The HTTP interface supports the following Web browser:

- Microsoft Internet Explorer 5.5 or later
 - Netscape 4.x or later
2. If necessary, disable the Internet proxy settings. For Internet Explorer users, follow these steps:
 - Select **Tools > Internet Options...**
 - Click the **Connections** tab.
 - Click **LAN Settings...**
 - If necessary, remove the check mark from the **Use a proxy server** box.
 - Click **OK** twice to save your changes and return to Internet Explorer.
 3. Enter the Access Point's IP address in the browser's **Address** field and press **Enter**.
 - Result: The **Enter Network Password** screen appears.
 4. Enter the HTTP password in the **Password** field and click **OK**. Leave the **User Name** field blank. (By default, the HTTP password is "public").
 - Result: The **System Status** screen appears.



Figure 6-1 Enter Network Password Screen

5. Click the **Commands** button located on the left-hand side of the screen.

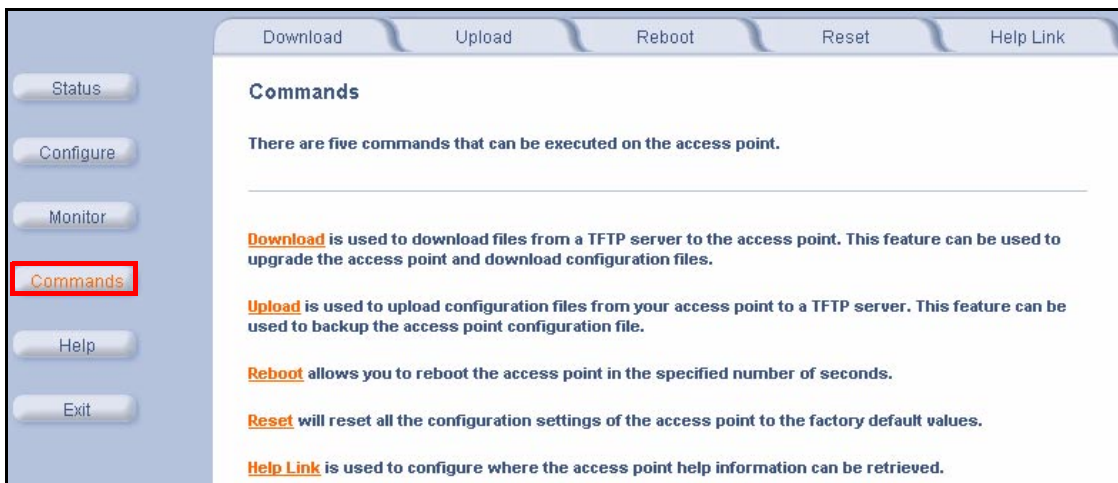

Figure 6-2 Commands Main Screen

6. Click the tab that corresponds to the command you want to issue. For example, click **Reboot** to restart the unit.

Download

Use the **Download** tab to download Configuration, AP Image, and Bootloader files to the AP-600. A TFTP server must be running and configured to point to the directory containing the file.

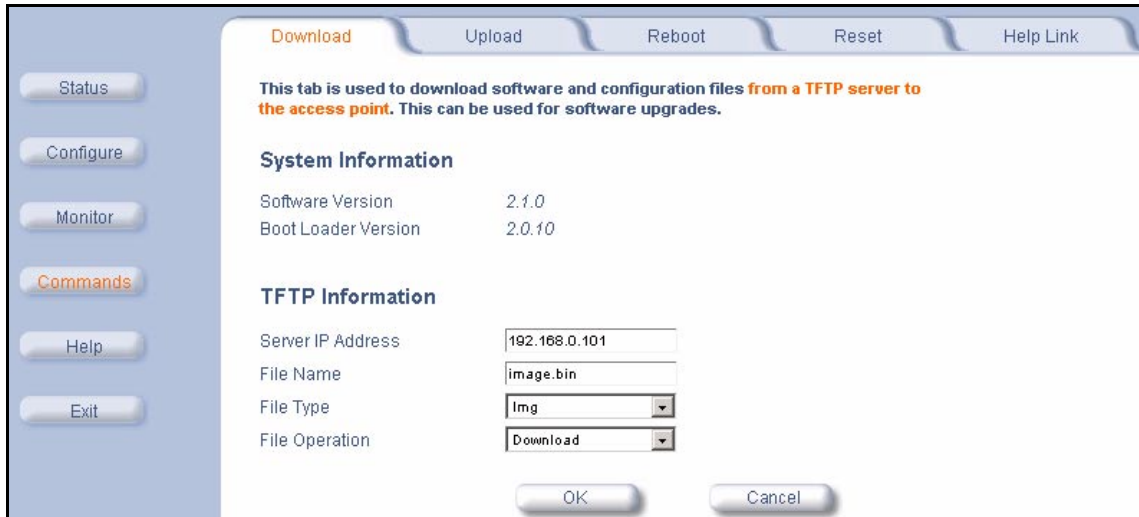

Figure 6-3 Download Command Screen

If you don't have a TFTP server installed on your system, install the TFTP server from the ORiNOCO CD. You can either install the TFTP server from the CD Wizard or run **OEM-TFTP-Server.exe** found in the CD's *Xtras/SolarWinds* sub-directory.

The **Download** tab shows version information and allows you to enter TFTP information as described below.

- **Server IP Address:** Enter the TFTP server IP Address.
 - Double-click the TFTP server icon on your desktop and locate the IP address assigned to the TFTP server.
Note: This is the IP address that will be used to point the Access Point to the AP Image file.
- **File Name:** Enter the name of the file to be downloaded (including the file extension).
 - Copy the updated AP Image file to the TFTP server's root folder. The default AP Image is located at *C:/Program Files/ORiNOCO/AP600/*.
- **File Type:** Select the proper file type. Choices include:
 - **Config** for configuration information, such as System Name, Contact Name, and so on.
 - **Img** for the AP Image (executable program).
 - **BspBI** for the Bootloader software.
- **File Operation:** Select either **Download** or **Download & Reboot**. You should reboot the AP-600 after downloading files.

Upload

Use the **Upload** tab to upload Configuration files from the AP-600. The TFTP server must be running and configured to point to the directory to which you want to copy the uploaded file. We suggest you assign the file a meaningful name, which may include version or location information.

If you don't have a TFTP server installed on your system, install the TFTP server from the ORiNOCO CD. You can either install the TFTP server from the CD Wizard or run **OEM-TFTP-Server.exe** found in the CD's *Xtras/SolarWinds* sub-directory.

- **Server IP Address:** Enter the TFTP server IP Address.
 - Double-click the TFTP server icon on your desktop and locate the IP address assigned to the TFTP server.
- **File Name:** Enter the name of the file to be uploaded.
- **File Type:** Select **Config**.
- **File Operation:** Select **Upload**.

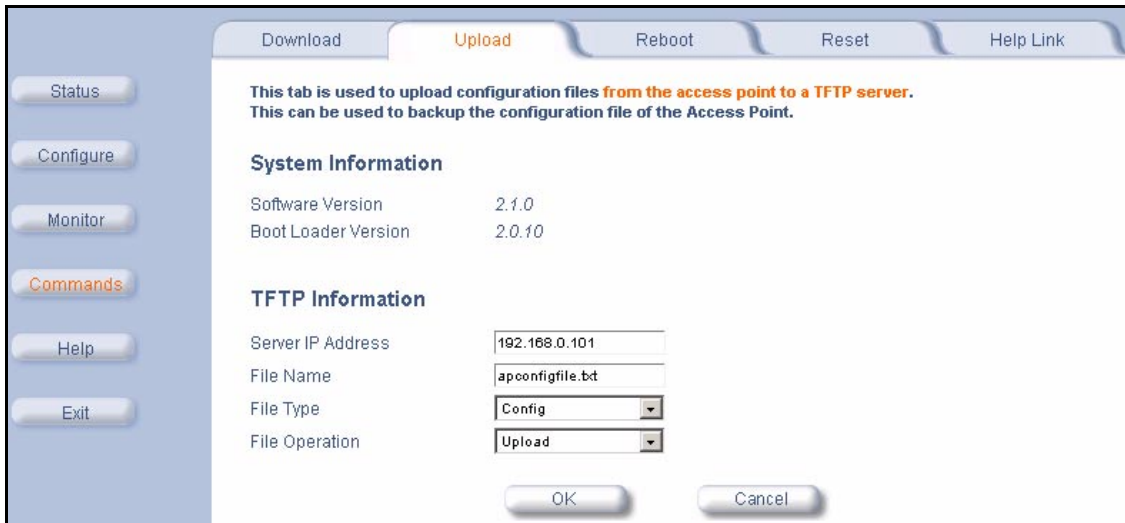

Figure 6-4 Upload Command Screen

Reboot

Use the **Reboot** tab to save configuration changes (if any) and reset the AP-600. Entering a value of 0 (zero) seconds causes an immediate reboot. Note that **Reset**, described below, does not save configuration changes.



CAUTION

Rebooting the AP-600 will cause all users who are currently connected to lose their connection to the network until the AP-600 has completed the restart process and resumed operation.

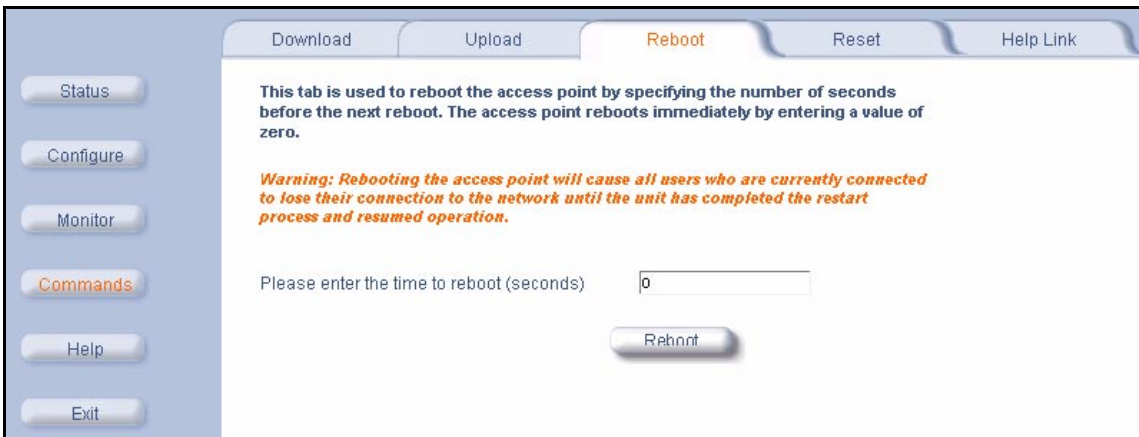

Figure 6-5 Reboot Command Screen

Reset

Use the **Reset** tab to restore the AP-600 to factory default conditions. The AP-600 may also be reset from the **RESET** button located on the side of the unit. Since this will reset the Access Point's current IP address, a new IP address must be assigned. Refer to [Recovery Procedures](#) for more information.



CAUTION

Resetting the AP-600 to its factory default configuration will permanently overwrite all changes that have made to the unit. The AP-600 will reboot automatically after this command has been issued.

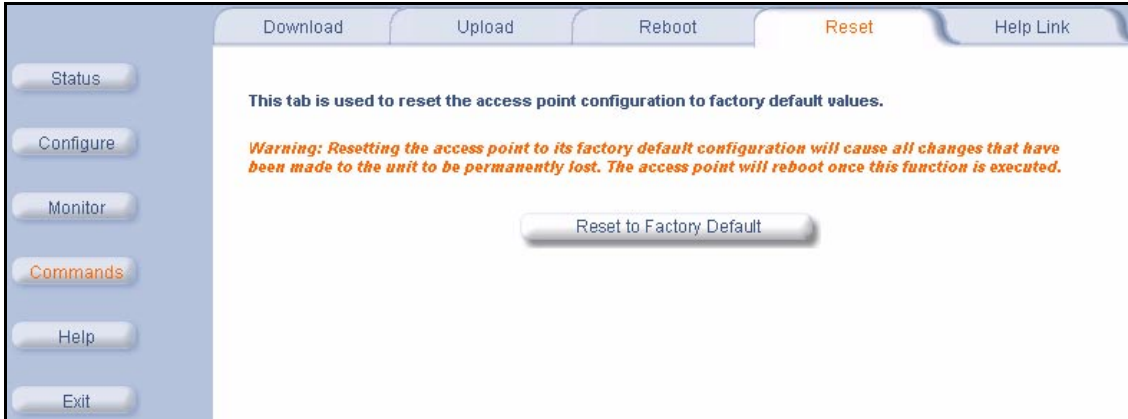

Figure 6-6 Reset to Factory Defaults Command Screen

Help Link

To open **Help**, click the **Help** button on any display screen.

During initialization, the AP-600 on-line help files are downloaded to the default location:
`C:\Program Files\ORiNOCO\AP600\HTML\index.htm`.

The ORiNOCO AP-600 Help information is available in English, French, German, Italian, Spanish, and Japanese. The Help files are copied to your computer in all six languages.

If you want to place these files on a shared drive, copy the Help Folder to the new location, and then specify the new path in the **Help Link** box.

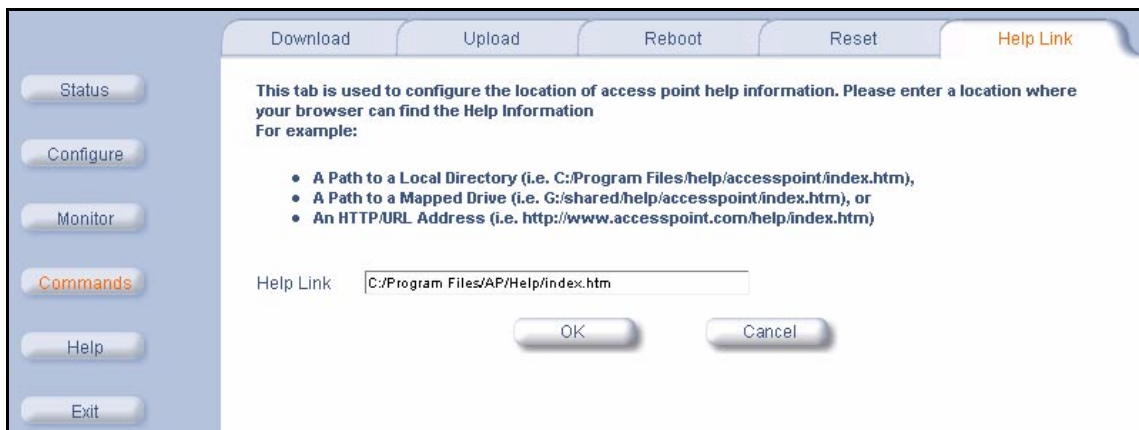

Figure 6-7 Help Link Configuration Screen

Troubleshooting

In This Chapter

If you are having problems with an AP-600, review the troubleshooting suggestions contained in this chapter.

- [Troubleshooting Concepts](#)
- [Symptoms and Solutions](#)
- [Recovery Procedures](#)
- [System Alarms \(Traps\)](#)
- [Related Applications](#)

NOTE

This section helps you locate problems related to the AP-600 device setup. For details about RADIUS, TFTP, serial communication programs (such as HyperTerminal), Telnet applications, or web browsers, please refer to the documentation that came with the application for assistance.

Troubleshooting Concepts

The following list identifies important troubleshooting concepts and topics. The most common initialization and installation problems relate to IP addressing. For example, you must have valid IP addresses for both the AP-600 and the management computer to access the unit's HTTP interface.

- **IP Address management is fundamental.**
- **Factory default units are set for "Dynamic" (DHCP) IP Address assignment.** The default IP address for the AP-600 is 169.254.128.132 if your network does not have a DHCP server. If you connect the AP-600 unit to a network with an active DHCP server, then use ScanTool to locate the IP address of your unit. If a DHCP server is not active on your subnet, then use ScanTool to assign a static IP address to the unit.
- **The Trivial File Transfer Protocol (TFTP) provides a means to download and upload files.** These files include the AP-600 Image (executable program) and configuration files.
- **If the AP-600 password is lost or forgotten, you will need to reset to default values.** The [Reset to Factory Default Procedure](#) resets configuration, but does not change the current AP Image.
- **If all else fails...** Use the [Forced Reload Procedure](#) to erase the current AP-600 Image and then download a new image. Once the new image is loaded, use the [Reset to Factory Default Procedure](#) to set the unit to factory default values and reconfigure the unit.
- **The AP-600 Supports a Command Line Interface (CLI).** If you are having trouble locating your AP-600 on the network, connect to the unit directly using the serial interface and refer to [Command Line Interface \(CLI\)](#) for CLI command syntax and parameter names.

Symptoms and Solutions

Connectivity Issues

Connectivity issues include any problem that prevents you from powering up or connecting to the AP-600.

AP-600 Unit Will Not Boot - No LED Activity

1. Make sure your power source is operating.
2. Make sure all cables are connected to the AP-600 correctly.
3. If you are using Active Ethernet, make sure you are using a Category 5, foiled, twisted pair cable to power the AP-600.

Serial Link Does Not Work

1. Make sure you are using a standard, straight-through, 9-pin serial cable.
2. Double-check the physical network connections.
3. Make sure your PC terminal program (such as HyperTerminal) is active and configured to the following values:
 - Com Port: (COM1, COM2, etc. depending on your computer);
 - Baud rate: 9600; Data bits: 8; Stop bits: 1; Flow Control: None; Parity: None;
 - Line Feeds with Carriage Returns
(In HyperTerminal select:
File -> Properties -> Settings -> ASCII Setup -> Send Line Ends with Line Feeds)

Ethernet Link Does Not Work

1. Double-check the physical network connections. Use a known-good unit to make sure the network connection is present. Once you have the AP-600 IP address, you can use the “Ping” command over Ethernet to test the IP Address. If the AP-600 responds to the Ping, then the Ethernet Interface is working properly.
2. By default, the Access Point will attempt to automatically detect the Ethernet settings. However, if you are having problems with the Ethernet link, manually configure the Access Point’s Ethernet settings. For example, if your switch operates at 100 Mbps/sec/Full Duplex, manually configure the Access Point to use these settings (see [Ethernet](#)). If you cannot access the unit over Ethernet, then use the CLI interface over the serial port to configure the Ethernet port (see [Command Line Interface \(CLI\)](#) and [Set Ethernet Speed and Transmission Mode](#)).
3. Perform network infrastructure troubleshooting (check switches, routers, etc.).

Basic Software Setup and Configuration Problems

Lost AP-600, Telnet, or SNMP Password

1. Perform the [Reset to Factory Default Procedure](#) in this guide. This procedure resets system and network parameters, but does not affect the AP-600 Image.
The default AP-600 HTTP password is “public”, and the default Telnet password is also “public”.

Client Computer Cannot Connect

1. Client computers should have the same Network Name and security settings as the AP-600.
2. Network Names should be allocated and maintained by the Network Administrator.
3. Refer to the documentation that came with your client card for additional troubleshooting suggestions.

AP-600 Has Incorrect IP Address

1. Default IP Address Assignment mode is dynamic (DHCP). If you do not have a DHCP server on your network, the default IP Address is **169.254.128.132**. If you have more than one uninitialized AP-600 connected to the network, they will all have the same default IP address and you will not be able to communicate with them (due to an IP address conflict). In this case, assign each AP a static IP address via the serial cable or turn off all units but one and change the IP address using ScanTool one at a time.

Troubleshooting

2. The AP-600 only contacts a DHCP server during boot-up. If your network's DHCP server is not available while the AP-600 is booting, the device will retain the last IP Address it had. Reboot the AP-600 once your DHCP server is on-line again or use the ScanTool to find the Access Point's current IP address.
3. To find the unit's current IP address if using DHCP, open the IP Client Table in the DHCP Server and match the Access Point's IP address to its MAC address (found on the product label). Alternatively, use ScanTool to identify an Access Point's current IP address.
4. Once you have the current IP address, use the HTTP or CLI Interface to change the unit's IP settings, if necessary.
5. If you use static IP Address assignments, and cannot access the unit over Ethernet, use the [Initializing the IP Address using CLI](#) procedure. Once the IP Address is set, you can use the Ethernet Interface to complete configuration.
6. Perform the [Reset to Factory Default Procedure](#) in this guide. This will reset the unit to "DHCP" mode. If there is a DHCP Server on the network, the DHCP Server will assign an IP Address to the AP-600.

HTTP (browser) or Telnet Interface Does Not Work

1. Make sure you are using a compatible browser: Microsoft Internet Explorer 5.5 or later (preferred), or Netscape 4.x or later.
2. Make sure you have the proper IP address. Enter your Access Point's IP Address in the browser address bar, similar to this example:
http://192.168.1.100
When the **Enter Network Password** window appears, leave the **User Name** field empty and enter the HTTP password in the **Password** field. The default HTTP password is "public".
3. Use the CLI over the serial port to check the IP Access Table, which can be restricting access to Telnet and HTTP.

HTML Help Files Do Not Appear

1. Verify that the HTML Help files are installed in the default directory:
`C:\Program Files\ORINOCO\AP600\HTML\`
2. If the Help files are not located in this folder, contact your network administrator to find out where the Help files are located on your server.
3. Perform the following steps to verify the location or to enter the pathname for the Help files:
 - a. Click the **Commands** button in the HTTP interface.
 - b. Select the **Help** tab located at the top of the screen.
 - c. Enter the pathname where the Help files are located in the **Help Link** box.
 - d. Click **OK** when finished.

Telnet CLI Does Not Work

1. Make sure you have the proper IP Address. Enter your AP-600 IP address in the Telnet connection dialog, from a DOS prompt, type:
C:\> telnet <AP-600 IP Address>
2. Confirm that your computer has an IP address in the same IP subnet as your Access Point.
3. Use the CLI over the serial port to check the IP Access Table, which can be restricting access to Telnet and HTTP.

TFTP Server Does Not Work

1. Make sure the TFTP Server has been started.
2. Verify the IP address of the TFTP Server. The server may be local or remote, so long as it has a valid IP address.
3. Configure the TFTP Server to "point" to the folder containing the file to be downloaded (or to the folder in which the file is to be uploaded).
4. Verify that you have entered the proper AP-600 Image file name (including the file extension) and directory path.
5. If you have a problem uploading a file, verify that the TFTP server is configured to allow uploads (typically the default setting is to allow only downloads).

Troubleshooting

Client Connection Problems

Client Software Finds No Connection

Make sure you have configured your client software with the proper Network Name and Security settings. Network Names and WEP Keys are typically allocated and maintained by your network administrator.

Client PC Card Does Not Work

1. Make sure you are using the latest PC Card driver software.
2. Download and install the latest ORiNOCO client software from <http://www.proxim.com>.

Intermittent Loss of Connection

1. Make sure you are within range of an active AP-600.
2. You can check the signal strength using the signal strength gauge on your ORiNOCO client software. If you are have an AP-600b, you can also use the Remote Link Test available in the Access Point's HTTP interface. See [Link Test \(AP-600b Only\)](#).

Client Does Not Receive an IP Address - Cannot Connect to Internet

1. If the AP-600 is configured as a DHCP server, open the Web-browser Interface and select the **Configure** button and then the **Network** tab to make sure the proper DHCP settings are being used.
2. If you are not using the DHCP server feature on the AP-600, then make sure that your local DHCP server is accessible from the Access Point's subnet.
3. From the client computer, use the "ping" network command to test the connection with the AP-600. If the AP-600 responds, but you still cannot connect to the Internet, there may be a physical network configuration problem (contact your network support staff).
4. If using Active Ethernet, make sure you are not using a crossover Ethernet cable between the AP-600 and the hub.

Active Ethernet (AE)

The AP-600 Does Not Work

1. Verify that you are using a standard UTP Category 5 cable.
2. Try a different port on the same AE hub (remember to move the input port accordingly) – if it works, there is probably a faulty port or bad RJ-45 port connection.
3. If possible, try to connect the AP-600 to a different AE hub.
4. Try using a different Ethernet cable – if it works, there is probably a faulty connection over the long cable, or a bad RJ-45 connection.
5. Check power plug and hub.
6. If the Ethernet link goes down, check the cable, cable type, switch, and hub.

There Is No Data Link

1. Verify that the indicator for the port is "on."
2. Verify that the AE hub is connected to the Ethernet network with a good connection.
3. Verify that the Ethernet cable is Category 5 or better and is less than 100 meters (approximately 325 feet) in length from the Ethernet source to the AP-600.
4. Try to connect a different device to the same port on the AE hub – if it works and a link is established, there is probably a faulty data link in the AP-600.
5. Try to re-connect the AP-600 to a different output port (remember to move the input port accordingly) – if it works, there is probably a faulty output or input port in the AE hub or a bad RJ-45 connection.

“Overload” Indications

1. Verify that you are not using a cross-over cable between the AE output port and the AP-600.
2. Verify that there is no short over any of the twisted pair cables.
3. Move the device into a different output port – if it works, there is probably a faulty port or bad RJ-45 connection.

Recovery Procedures

The most common installation problems relate to IP addressing. For example, without the TFTP server IP Address, you will not be able to download a new AP Image to the AP-600. IP Address management is fundamental. We suggest you create a chart to document and validate the IP addresses for your system.

If the password is lost or forgotten, you will need to reset the AP-600 to default values. The [Reset to Factory Default Procedure](#) resets configuration settings, but does not change the current AP Image.

If the AP-600 has a corrupted software image, follow the [Forced Reload Procedure](#) to erase the current AP Image and download a new image.

Reset to Factory Default Procedure

Use this procedure to reset the network configuration values, including the Access Point's IP address and subnet mask. The current AP Image is not deleted. Follow this procedure if you forget the Access Point's password:

1. Press and hold the **RELOAD** button for 10 seconds.

➤ NOTE

See [RELOAD and RESET Buttons](#) to identify the buttons. You need to use a pin or the end of a paperclip to press a button.

Result: The AP-600 reboots, and the factory default network values are restored.

2. If not using DHCP, use the ScanTool or CLI over a serial connection to set the IP address, subnet mask, and other IP parameters. See [Command Line Interface \(CLI\)](#) for CLI information.

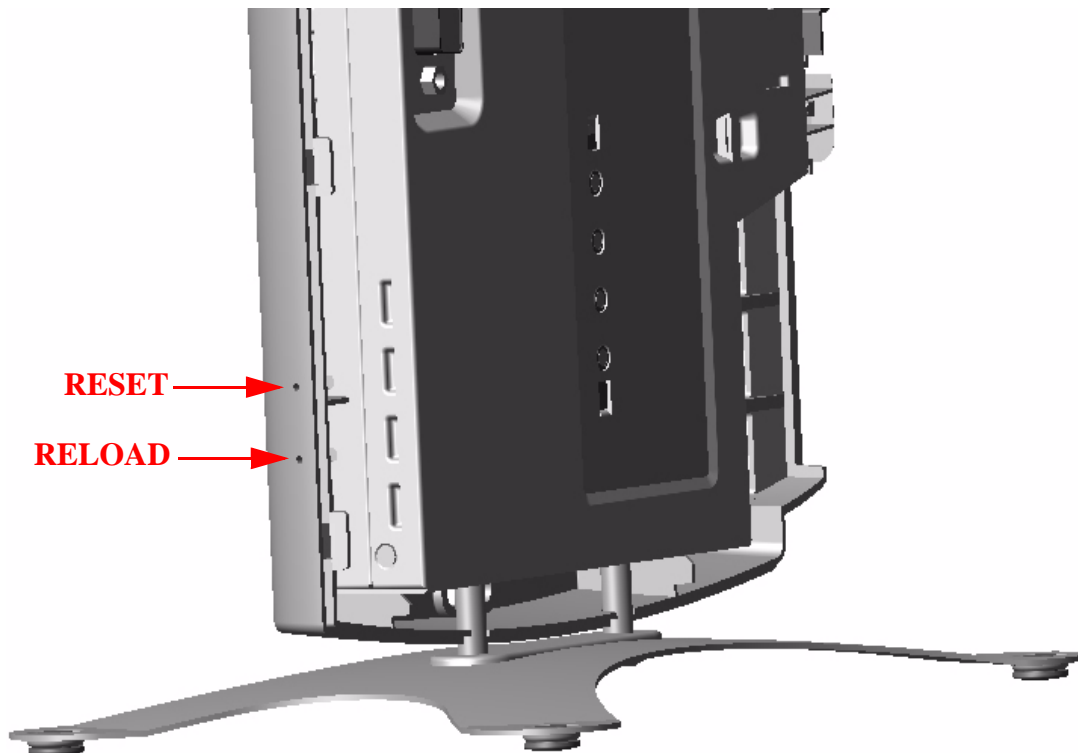

Figure 7-1 RELOAD and RESET Buttons

Forced Reload Procedure

Use this procedure to erase the current AP Image and download a new AP Image. In some cases, specifically when a missing or corrupted AP Image prevents successful booting, you may need to use ScanTool or the Bootloader CLI to download a new executable AP Image.

NOTE

This does not delete the AP-600's configuration (in other words, the Forced Reload Procedure does not reset to device to factory defaults). If you need to force the AP-600 to the factory default state after loading a new AP image, use the [Reset to Factory Default Procedure](#) above.

For this procedure, you will first erase the AP Image currently installed on the unit and then use either ScanTool or the Bootloader CLI (over the serial port) to set the IP address and download a new AP Image. Follow these steps:

1. While the unit is running, press the **RESET** button.

NOTE

See [RELOAD and RESET Buttons](#) to identify the buttons. You need to use a pin or the end of a paperclip to press a button.

Result: The AP-600 reboots and the indicators begin to flash.

CAUTION

By completing Step 2, the firmware in the AP-600 will be erased. You will need an Ethernet connection, a TFTP server, and a serial cable (if using the Bootloader CLI) to reload firmware.

2. Press and hold the **RELOAD** button for about 20 seconds until the **POWER LED** turns amber.

Result: The AP-600 deletes the current AP Image.

3. Follow one of the procedures below to load a new AP Image to the Access Point:

- [Download a New Image Using ScanTool](#)
- [Download a New Image Using the Bootloader CLI](#)

Download a New Image Using ScanTool

To download the AP Image, you will need an Ethernet connection to the computer on which the TFTP server resides and to a computer that is running ScanTool (this is either two separate computers connected to the same network or a single computer running both programs).

ScanTool detects if an Access Point does not have a valid software image installed. In this case, the **TFTP Server** and **Image File Name** parameters are enabled in the ScanTool's **Change** screen so you can download a new image to the unit. (These fields are grayed out if ScanTool does not detect a software image problem.)

Preparing to Download the AP Image

Before starting, you need to know the Access Point's IP address, subnet mask, the TFTP Server IP Address, and the AP Image file name. Make sure the TFTP server is running and configured to point to the folder containing the image to be downloaded.

Download Procedure

Follow these steps to use ScanTool to download a software image to an Access Point with a missing image:

1. Download the latest software from <http://www.proxim.com>.
2. Copy the latest software updates to your TFTP server.
3. Launch ScanTool.
4. Highlight the entry for the AP-600 you want to update and click **Change**.
5. Set **IP Address Type** to **Static**.

NOTE

You need to assign static IP information temporarily to the Access Point since its DHCP client functionality is not available when no image is installed on the device.

6. Enter an unused IP address that is valid on your network in the **IP Address** field. You may need to contact your network administrator to get this address.
7. Enter the network's **Subnet Mask** in the field provided.
8. Enter the network's **Gateway IP Address**, if necessary. You may need to contact your network administrator to get this address. You should only need to enter the default gateway address if the Access Point and the TFTP server are separated by a router.
9. Enter the IP address of your TFTP server in the field provided.
10. Enter the **Image File Name** (including the file extension). Enter the full directory path and file name. If the file is located in the default TFTP directory, you need enter only the file name.
11. Click **OK**.
 - Result: The Access Point will reboot and the download will begin automatically. You should see downloading activity begin after a few seconds within the TFTP server's status screen.
12. Click **OK** when prompted that the device has been updated successfully to return to the **Scan List** screen.
13. Click **Cancel** to close the ScanTool.
14. When the download process is complete, configure the AP-600 as described in [Installation & Basic Configuration](#) and [Advanced Configuration](#).

Download a New Image Using the Bootloader CLI

To download the AP Image, you will need an Ethernet connection to the computer on which the TFTP server resides. This can be any computer on the LAN or connected to the AP-600 with a cross-over Ethernet cable.

You must also connect the AP-600 to a computer with a standard serial cable and use a terminal client, such as HyperTerminal. From the terminal, enter CLI Commands to set the IP address and download an AP Image.

Preparing to Download the AP Image

Before starting, you need to know the Access Point's IP address, subnet mask, the TFTP Server IP Address, and the AP Image file name. Make sure the TFTP server is running and configured to point to the folder containing the image to be downloaded.

Download Procedure

1. Download the latest software from <http://www.proxim.com>.
2. Copy the latest software updates to your TFTP server's default directory.
3. Use a straight-through serial cable to connect the Access Point's serial port to your computer's serial port.

NOTE

You must remove the Access Point's cable cover and front cover to access the serial port.

4. Open your terminal emulation program (like HyperTerminal) and set the following connection properties:
 - Com Port: <COM1, COM2, etc., depending on your computer>
 - Baud rate: 9600
 - Data Bits: 8
 - Stop bits: 1
 - Flow Control: None
 - Parity: None
5. Under **File -> Properties -> Settings -> ASCII Setup**, enable the **Send line ends with line feeds** option.
Result: HyperTerminal sends a line return at the end of each line of code.
6. Press the **RESET** button on the AP-600.
Result: The terminal display shows Power On Self Tests (POST) activity. After approximately 30 seconds, a message indicates: **Sending Traps to SNMP manager periodically**. After this message appears, press the **ENTER** key repeatedly until the following prompt appears:

```
[Device name]>
```

Troubleshooting

7. Enter only the following statements:

```
[Device name]> set ipaddrtype static
[Device name]> set ipaddr <Access Point IP Address>
[Device name]> set ipsubmask <IP Mask>
[Device name]> set tftpipaddr <TFTP Server IP Address>
[Device name]> set tftpfilename <AP Image File Name, including file extension>
[Device name]> set ipgw <Gateway IP Address>
[Device name]> show ip (to confirm your new settings)
[Device name]> show tftp (to confirm your new settings)
[Device name]> reboot 0
```

Example:

```
[Device name]> set ipaddrtype static
[Device name]> set ipaddr 10.0.0.12
[Device name]> set ipsubmask 255.255.255.0
[Device name]> set tftpipaddr 10.0.0.20
[Device name]> set tftpfilename MyImage.bin
[Device name]> set ipgw 10.0.0.30
[Device name]> show ip
[Device name]> show tftp
[Device name]> reboot 0
```

Result: The AP-600 will reboot and then download the image file. You should see downloading activity begin after a few seconds within the TFTP server's status screen.

8. When the download process is complete, configure the AP-600 as described in [Installation & Basic Configuration](#) and [Advanced Configuration](#).

Setting IP Address using Serial Port and Normal CLI

Use the following procedure to set an IP address over the serial port using the CLI. The network administrator typically provides the AP-600 IP address.

Hardware and Software Requirements

- Standard straight-through serial data (RS-232) cable with a one male DB-9 connector and one female DB-9 connector. The AP-600 comes with a female 9-pin serial port.
- ASCII Terminal software, such as HyperTerminal.

Attaching the Serial Port Cable

1. Unlock and remove the cable cover from the AP-600.
2. Remove the front cover from the AP-600 to reveal the serial port.
3. Connect one end of the serial cable to the AP-600 and the other end to a serial port on your computer.
4. Power on the computer and AP-600, if necessary.

Initializing the IP Address using CLI

After installing the serial port cable, you may use the CLI to communicate with the AP-600. CLI supports most generic terminal emulation programs, such as HyperTerminal (which is included with the Windows operating systems). In addition, many web sites offer shareware or commercial terminal programs you can download. Once the IP address has been assigned, you can use the HTTP interface or the CLI over Telnet to complete configuration.

Troubleshooting

Follow these steps to assign the AP-600 an IP address:

1. Open your terminal emulation program (like HyperTerminal) and set the following connection properties:
 - Com Port: <COM1, COM2, etc., depending on your computer>
 - Baud rate: 9600
 - Data Bits: 8
 - Stop bits: 1
 - Flow Control: None
 - Parity: None
2. Under **File -> Properties -> Settings -> ASCII Setup**, enable the **Send line ends with line feeds** option.
Result: HyperTerminal sends a line return at the end of each line of code.
3. Press the **RESET** button on the AP-600 (see [RELOAD and RESET Buttons](#) to identify the location of the **RESET** button).
Result: The terminal display shows Power On Self Tests (POST) activity, and then displays a CLI prompt, similar to the example below. This process may take up to 90 seconds.
[Device name]> **Please enter password:**
4. Enter the CLI password (default is **public**).
Result: The terminal displays a welcome message and then the CLI Prompt:
[Device name]>
5. Enter **show ip**. Result: Network parameters appear:

```
[Device Name]> show ip
IP/Network Group Parameters
=====
ipaddr      :      10.0.0.1
ipsubmask   :      255.0.0.0
ipgw        :      10.0.0.1
ipttl       :      64
ipaddrtype  :      static
[Device Name]> _
```

Figure 7-2 Result of “show ip” CLI Command

6. Change the IP address and other network values using **set** and **reboot** CLI commands, similar to the example below (use your own IP address and subnet mask). Note that IP Address Type is set to Dynamic by default. If you have a DHCP server on your network, you should not need to manually configure the Access Point’s IP address; the Access Point will obtain an IP address from the network’s DHCP server during boot-up.
Result: After each entry the CLI reminds you to reboot; however wait to reboot until all commands have been entered.
[Device name]> **set ipaddrtype static**
[Device name]> **set ipaddr <IP Address>**
[Device name]> **set ipsubmask <IP Subnet Mask>**
[Device name]> **set ipgw <Default Gateway IP Address>**
[Device name]> **show ip** (to confirm your new settings)
[Device name]> **reboot 0**
7. After the AP-600 reboots, verify the new IP address by reconnecting to the CLI and enter a **show ip** command. Alternatively, you can ping the AP-600 from a network computer to confirm that the new IP address has taken effect.
8. When the proper IP address is set, use the HTTP interface or CLI over Telnet to configure the rest of the unit’s operating parameters.

Troubleshooting

System Alarms (Traps)

Security Alarms

oriTrapAuthenticationFailure	A client has failed to authenticate using one of the following authentication methods: MAC Access Control Table, RADIUS MAC Authentication, or 802.1x Authentication (for 802.1x, EAP type is specified)
oriTrapUnauthorizedManagerDetected	An unauthorized manager has attempted to view and/or modify parameters

Wireless Interface Card Alarms

oriTrapWLCNotPresent	Wireless radio not present
oriTrapWLCFailure	Wireless radio general failure
riTrapWLCRemoval	Wireless radio removal
oriTrapWLCIncompatibleFirmware	Wireless radio incompatible firmware detected
oriTrapWLCVoltageDiscrepancy	Wireless radio voltage discrepancy detected
oriTrapWLCIncompatibleVendor	Wireless radio incompatible vendor detected
oriTrapWLCFirmwareDownloadFailure	Wireless radio firmware download failure detected

Operational Alarms

oriTrapWatchDogTimerExpired	Watch Dog Timer has expired
oriTrapRADIUSServerNotResponding	RADIUS Server is not responding or error communicating with RADIUS Server
oriTrapModuleNotInitialized	Module has not been initialized
oriTrapDeviceRebooting	Device is rebooting
oriTrapTaskSuspended	Task suspension has been detected
oriTrapBootPFailed	BootP failure detected (no response from BootP Server)
oriTrapDHCPFailed	DHCP Client failure detected (no response from DHCP server)

FLASH Memory Alarms

oriTrapFlashMemoryEmpty	Flash memory empty
oriTrapFlashMemoryCorrupted	Flash memory data corrupted

TFTP Alarms

oriTrapTFTPFailedOperation	TFTP (upload or download) failure detected
oriTrapTFTPOperationInitiated	TFTP (upload or download) operation initiated
oriTrapTFTPOperationCompleted	TFTP (upload or download) operation completed

Image Alarms

oriTrapZeroSizeImage	Zero size image has been downloaded to device
oriTrapInvalidImage	Invalid image has been downloaded to device
oriTrapImageTooLarge	Image downloaded to device is too big
oriTrapIncompatibleImage	Incompatible image has been downloaded to device

Standard MIB-II (RFC 1213) Alarms

coldStart	Device has been turned on or rebooted
linkUp	Device Link is up (Ethernet interface is up)
linkDown	Device Link is down (Ethernet interface is down)

Troubleshooting

Bridge MIB (RFC 1493) Alarms

newRoot	New root has been added to Bridge
topologyChange	Network Topology change has been detected

Related Applications

RADIUS Authentication Server

If you enabled RADIUS Authentication on the AP-600, make sure that your network's RADIUS servers are operational. Otherwise, clients will not be able to log in. There are several reasons the authentication server services might be unavailable, here are two typical things to check:

- Make sure you have the proper RADIUS authentication server information setup configured in the AP-600. Check the RADIUS Authentication Server's Shared Secret and Destination Port number (default is 1812; for RADIUS Accounting, the default is 1813).
- Make sure the RADIUS authentication server RAS setup matches the AP-600.

TFTP Server

The "Trivial File Transfer Protocol" (TFTP) server allows you to transfer files across a network. You can upload configuration files from the AP-600 for backup or copying, and you can download configuration files or new software images. The TFTP software is located on the ORiNOCO AP-600 Installation CD-ROM.

If a TFTP server is not configured and running, you will not be able to download and upload images and configuration files to/from the AP-600. Remember that the TFTP server does not have to be local, so long as you have a valid TFTP IP address. Note that you do not need a TFTP server running unless you want to transfer files to or from the AP-600.

After the TFTP server is installed:

- Check to see that TFTP is configured to point to the directory containing the AP Image.
- Make sure you have the proper TFTP server IP Address, the proper AP Image file name, and that the TFTP server is connected.
- **Make sure the TFTP server is configured to both send and receive, with no time-out.**



Command Line Interface (CLI)

In This Appendix

This section describes the AP-600's Command Line (CLI) Interface. CLI commands can be used to initialize, configure, and manage the Access Point.

- CLI commands may be entered in real time through a keyboard or submitted with CLI scripts.
- The CLI is available through both the Serial Port interface and over the Ethernet interface using Telnet.



NOTE

All CLI commands and parameters are case-sensitive.

- [General Notes](#)
- [Command Line Interface \(CLI\) Variations](#)
- [CLI Command Types](#)
- [Using Tables & User Strings](#)
- [Configuring the AP-600 using CLI commands](#)
- [Set Basic Configuration Parameters using CLI Commands](#)
- [Other Network Settings](#)
- [CLI Monitoring Parameters](#)
- [Parameter Tables](#)

General Notes

Prerequisite Skills and Knowledge

To use this document effectively, you should have a working knowledge of Local Area Networking (LAN) concepts, network access infrastructures, and client-server relationships. In addition, you should be familiar with software setup procedures for typical network operating systems and servers.

Notation Conventions

- Computer prompts are shown as constant width type. For example: `[Device name]>`
- Information that you input as shown is displayed in bold constant width type. For example:
`[Device name]> set ipaddr 10.0.0.12`
- The names of keyboard keys, software buttons, and field names are displayed in bold type. For example: Click the **Configure** button.
- Screen names are displayed in bold italics. For example, the ***System Status*** screen.

Important Terminology

- Configuration Files - Database files containing the current Access Point configuration. Configuration items include the IP Address and other network-specific values. Config files may be downloaded to the Access Point or uploaded for backup or troubleshooting.
- Download vs. Upload - Downloads transfer files to the Access Point. Uploads transfer files from the Access Point. The TFTP server performs file transfers in both directions.

Command Line Interface (CLI)

- Group - A logical collection of network parameter information. For example, the System Group is composed of several related parameters. Groups can also contain Tables. All items for a given Group can be displayed with a **show <Group>** CLI Command.
- Image File - The Access Point software executed from RAM. To update an Access Point you typically download a new Image File. This file is often referred to as the "AP Image".
- Parameter - A fundamental network value that can be displayed and may be changeable. For example, the Access Point must have a unique IP Address and the Wireless interface must be assigned an SSID. Change parameters with the CLI **set** Command, and view them with the CLI **show** Command.
- Table - Tables hold parameters for several related items. For example, you can add several potential managers to the SNMP Table. All items for a given Table can be displayed with a **show <Table>** CLI Command.
- TFTP - Refers to the TFTP Server, used for file transfers.

Navigation and Special Keys

This CLI supports the following navigation and special key functions to move the cursor along the prompt line.

Key Combination	Operation
Delete or Backspace	Delete previous character
Ctrl-A	Move cursor to beginning of line
Ctrl-E	Move cursor to end of line
Ctrl-F	Move cursor forward one character
Ctrl-B	Move cursor back one character
Ctrl-D	Delete the character the cursor is on
Ctrl-U	Delete all text to left of cursor
Ctrl-P	Go to the previous line in the history buffer
Ctrl-N	Go to the next line in the history buffer
Tab	Complete the command line
?	List available commands

CLI Error Messages

The following table describes the error messages associated with improper inputs or expected CLI behavior.

Error Message	Description
Syntax error	Invalid syntax entered at the command prompt.
Invalid command	A non-existent command has been entered at the command prompt.
Invalid parameter name	An invalid parameter name has been entered at the command prompt.
Invalid parameter value	An invalid parameter value has been entered at the command prompt.
Invalid table index	An invalid table index has been entered at the command prompt.
Invalid table parameter	An invalid table parameter has been entered at the command prompt.
Invalid table parameter value	An invalid table parameter value has been entered at the command prompt.
Read only parameter	User is attempting to configure a read-only parameter.
Incorrect password	An incorrect password has been entered in the CLI login prompt.
Download unsuccessful	The download operation has failed due to incorrect TFTP server IP Address or file name.
Upload unsuccessful	The upload operation has failed due to incorrect TFTP server IP Address or file name.

Command Line Interface (CLI) Variations

Administrators use the CLI to control Access Point operation and monitor network statistics. The AP-600 supports two types of CLI: the Bootloader CLI and the normal CLI. The Bootloader CLI provides a limited command set, and is used when the current AP Image is bad or missing. The Bootloader CLI allows you to assign an IP Address and download a new image. Once the image is downloaded and running, the Access Point uses the normal CLI. This guide covers the normal CLI unless otherwise specified.

Command Line Interface (CLI)

Bootloader CLI

The Bootloader CLI is a minimal subset of the normal CLI used to perform initial configuration of the AP-600. This interface is only accessible via the serial interface if the AP-600 does not contain a software image or a download image command over TFTP has failed.

The Bootloader CLI provides you with the ability to configure the initial setup parameters as well as download a software image to the device.

The following functions are supported by the Bootloader CLI:

- configuration of initial device parameters using the **set** command
- **show** command to view the device's configuration parameters
- **help** command to provide additional information on all commands supported by the Bootloader CLI
- **reboot** command to reboot the device

The parameters supported by the Bootloader CLI (for viewing and modifying) are:

- System Name
- IP Address Assignment Type
- IP Address
- IP Mask
- Gateway IP Address
- TFTP Server IP Address
- Image File Name (including the file extension)

The following lists display the results of using the **help** command in the Bootloader CLI:

```
[Device name]> help
Command List      Description
=====
set               Set system parameters
show             Show running system information
help            Description of commands, command usage and parameters
reboot          reboot the target

Command Usage
=====
set <parameter name> <parameter value> <cr>
show <cr>
help <cr>
reboot <cr>

Parameter List   Description
=====
sysname         System Name
ipaddr          System IP Address
ipsubmask       System Subnet Mask
ipgw            System Default Gateway IP Address
tftpipaddr      TFTP Server IP Address
tftpfilename    Image or Binary File name
ipaddrtype      System IP Address Type - STATIC or DYNAMIC

[Device name]>
```

Figure A-1 Results of “help” bootloader CLI command

The following lists display the results of using the **show** command in the Bootloader CLI:

```
[Device name]> show

sysname         Device name      System Name
ipaddr          10.0.0.1         System IP Address
ipsubmask       255.0.0.0        System Subnet Mask
ipgw            10.0.0.1         System Default Gateway IP Address
ipaddrtype      DYNAMIC          IP Address type
tftpipaddr      10.0.0.2         TFTP Server IP Address
tftpfilename    FILENAME         Image or Binary File Name

[Device name]>
```

Figure A-2 Results of “show” bootloader CLI command

Command Line Interface (CLI)

CLI Command Types

This guide divides CLI Commands into two categories: Operational and Parameter Controls.

Operational CLI Commands

These commands affect Access Point behavior, such as downloading, rebooting, and so on. After entering commands (and parameters, if any) press the **Enter** key to execute the Command Line.

Operational commands include:

- **?**: Typing a question mark lists CLI Commands or parameters, depending on usage (you do not need to type Enter after typing this command)
- **done, exit, quit**: Terminates the CLI session
- **download**: Uses TFTP server to download “image”, “config”, or “bootloader upgrade” files to Access Point
- **help**: Displays general CLI help information or command help information, such as command usage and syntax
- **history**: Remembers commands to help avoid re-entering complex statements
- **passwd**: Sets the Access Point’s CLI password
- **reboot**: Reboots the Access Point in the specified time
- **search**: Lists the parameters in a specified Table
- **upload**: Uses TFTP server to upload “config” files from Access Point to TFTP default directory or specified path

? (List Commands)

This command can be used in a number of ways to display available commands and parameters.

The following table lists each operation and provides a basic example. Following the table are detailed examples and display results for each operation.

Operation	Basic Example
Display the Command List (Example 1)	[Device Name] >?
Display commands that start with specified letters (Example 2)	[Device Name] > s ?
Display parameters for set and show Commands (Examples 3a and 3b)	[Device Name] > set ? [Device Name] > show ipa?
Prompt to enter successive parameters for Commands (Example 4)	[Device Name] > download ?

Example 1. Display Command list

To display the Command List, enter ?.

[Device Name] >?

```
[Device Name]>
show
set
download
upload
reboot
passwd
help
quit
done
exit
history
search
[Device Name] > _
```

Figure A-3 Result of “?” CLI command

Example 2. Display specific Commands

To show all commands that start with specified letters, enter one or more letters, then ? with no space between letters and ?.

[Device Name] >**s**?

Command Line Interface (CLI)

```
[Device Name] > s
show          set          search
```

Figure A-4 Result of “s?” CLI command

Example 3. Display parameters for set and show

Example 3a allows you to see every possible parameter for the set (or show) commands. Notice from example 3a that the list is very long. Example 3b shows how to display a subset of the parameters based on initial parameter letters.

Example 3a. Display every parameter that can be changed

```
[Device Name] > set ?
```

```
[Device Name] > set
Command Description:
The set command modifies the value of a given scalar parameter or table entry.

Command Usage:
set <parameter> <parameter value> <CR>
set <table> <index> <arg1> <value1> ..... <argN> <valueN> <CR>

Example:
set sysname "My Wireless Device" <CR>
set mgmtipaccess tbl 0 ipaddr 10.0.0.10 ipmask 255.255.0.0 cmt "Test WorkStation"
<CR>

[Device Name] > set
broadcastfltbl
dncp gw
dncp ip pooltbl
dncp pri dns ipaddr
dncp sec dns ipaddr
dncp status
dncp domain name
dncp pri svr ipaddr
dncp sec svr ipaddr
dncp status
etherfltbl ifbitmask
.
.
.
.
tel session timeout
tftp filename
tftp filetype
tftp ipaddr
vlan idtbl
vlan mgmt id
vlan status
wdstbl
wif
wifsec
[Device Name] > set _
```

Figure A-5 Result of “set ?” CLI command

Example 3b. Display parameters based on letter sequence

This example shows entries for parameters that start with the letter “i”. The more letters you enter, the fewer the results returned. Notice that there is no space between the letters and the question mark.

```
[Device Name] > show ipa?
```

```
[Device Name] > show ipa
ipaddr          ipaddrtype      iparp
iparpfltblipaddr  iparpfltblstatus  iparpfltblsubmask
```

Figure A-6 Result of “show ipa?” CLI command

```
[Device Name] > show iparp?
```

```
[Device Name] > show iparp
iparp          iparpfltblipaddr  iparpfltblstatus
iparpfltblsubmask
[Device Name] > show iparp_
```

Figure A-7 Result of “show iparp?” CLI command

Command Line Interface (CLI)

Example 4. Display Prompts for Successive Parameters

Enter the command, a space, and then ?. Then, when the parameter prompt appears, enter the parameter value. Result: The parameter is changed and a new CLI line is echoed with the new value (in the first part of the following example, the value is the IP Address of the TFTP server).

After entering one parameter, you may add another ? to the new CLI line to see the next parameter prompt, and so on until you have entered all of the required parameters. The following example shows how this is used for the **download** Command. The last part of the example shows the completed **download** Command ready for execution.

```
[Device Name]> download ?
<TFTP IP Address>
[Device Name]> download 169.254.128.133 ?
<File Name>
[Device Name]> download 169.254.128.133 apimage ?
<file type (config/img/bootloader)>
[Device Name]> download 169.254.128.133 apimage img <CR>
```

done, exit, quit

Each of the following commands ends a CLI session:

```
[Device Name]> done
[Device Name]> exit
[Device Name]> quit
```

download

Downloads the specified file from a TFTP server to the Access Point. Executing **download** in combination with the asterisks character ("*") will make use of the previously set TFTP parameters. Executing **download** without parameters will display command help and usage information.

1. Syntax to download a file:

```
Device Name]>download <tftp server address> <path and filename> <file type>
```

Example:

```
[Device Name]>download 192.168.1.100 APImage2 img
```

2. Syntax to display help and usage information:

```
[Device Name]>download
```

3. Syntax to execute the download Command using previously set (stored) TFTP Parameters:

```
[Device Name]>download *
```

help

Displays instructions on using control-key sequences for navigating a Command Line and displays command information and examples.

1. Using help as the only argument:

```
[Device Name]>help
```

Command Line Interface (CLI)

```
[Device Name]> help
Type ? at the command prompt for a command list.

Complete command description and command usage can be provided by:
help <command name> <CR>
<command name> help <CR>

Special keys supported:
Arrow Keys
DEL, BS .... delete previous character
Ctrl-A .... go to beginning of line
Ctrl-E .... go to end of line
Ctrl-F .... go forward one character
Ctrl-B .... go backward one character
Ctrl-D .... delete current character
Ctrl-U, # ... delete to beginning of line
Ctrl-K .... delete to end of line
Ctrl-W .... delete previous word
Ctrl-T .... transpose previous character
Ctrl-P .... go to previous line in history buffer
Ctrl-N .... go to next line in history buffer

Tab .... will attempt command completion
# .... Comment Character
? .... will provide command listing

Examples:
'? '      list all the supported commands
'sh?'    list all commands that start with sh
'show ?'  list all arguments to the show command
'sh<TAB>' complete the 'show' command

[Device Name]>
```

Figure A-8 Results of “help” CLI command

2. Complete command description and command usage can be provided by:

```
[Device Name]>help <command name>
[Device Name]><command name> help
```

history

Shows content of Command History Buffer. The Command History Buffer stores command statements entered in the current session. To avoid re-entering long command statements, use the keyboard “up arrow” (Ctrl-P) and “down arrow” (Ctrl-N) keys to recall previous statements from the Command History Buffer. When the desired statement reappears, press the **Enter** key to execute, or you may edit the statement before executing it.

```
[Device Name]> history
```

passwd

Changes the CLI Password.

```
[Device Name]> passwd oldpassword newpassword newpassword
```

reboot

Reboots Access Point after specified number of seconds. Specify a value of 0 (zero) for immediate reboot.

```
[Device Name]> reboot 0
[Device Name]> reboot 30
```

search

Lists the parameters supported by the specified table. This list corresponds to the table information displayed in the HTTP interface. In this example, the CLI returns the list of parameters that make up an entry in the IP Access Table.

```
[Device Name]> search mgmtipaccesstbl
```

Command Line Interface (CLI)

```
[Device Name]> search mgmtipaccesstbl
The supported elements are:
index
ipaddr
ipmask
cmt
status
```

Figure A-9 Results of “search mgmtipaccesstbl” CLI command

upload

Uploads a text-based configuration file from the AP-600 to the TFTP Server. Executing **upload** with the asterisk character (“*”) will make use of the previously set/stored TFTP parameters. Executing **upload** without parameters will display command help and usage information.

1. Syntax to upload a file:

```
[Device Name]>upload <tftp server address> <path and filename> <filetype>
```

Example:

```
[Device Name]>upload 192.168.1.100 APconfig.sys config
```

2. Syntax to display help and usage information:

```
[Device Name]>help upload
```

3. Syntax to execute the upload command using previously set (stored) TFTP Parameters:

```
[Device Name]>upload *
```

Parameter Control Commands

The following sections cover the two Parameter Control Commands (**show** and **set**) and include several tables showing parameter properties. These commands allow you to view (**show**) all parameters and statistics and to change (**set**) parameters.

- **show:** To see any Parameter or Statistic value, you can specify a single parameter, a Group, or a Table.
- **set:** Use this CLI Command to change parameter values. You can use a single CLI statement to modify Tables, or you can modify each parameter separately.

“show” CLI Command

Displays the value of the specified parameter, or displays all parameter values of a specified group (parameter table). Groups contain Parameters and Tables. Tables contain parameters for a series of similar entities.

To see a definition and syntax example, type only **show** and then press the **Enter** key. To see a list of available parameters, enter a question mark (?) after **show** (example: **show ?**).

Syntax:

```
[Device Name]>show <parameter>
[Device Name]>show <group>
[Device Name]>show <table>
```

Examples:

```
[Device Name]>show ipaddr
[Device Name]>show network
[Device Name]>show mgmtipaccesstbl
```

“set” CLI Command

Sets (modifies) the value of the specified parameter. To see a definition and syntax example, type only **set** and then press the **Enter** key. To see a list of available parameters, enter a space, then a question mark (?) after **set** (example: **set?**).

Command Line Interface (CLI)

Syntax:

```
[Device Name]>set <parameter> <value>  
[Device Name]>set <table> <index> <argument 1> <value 1> ... <argument N> <value N>
```

Example:

```
[Device Name]>set sysloc "Main Lobby"  
[Device Name]>set mgmtipaccessstbl 0 ipaddr 10.0.0.10 submask 255.255.0.0
```

Configuring Objects that Require Reboot

Certain objects supported by the Access Point require a device reboot in order for the changes to take effect. In order to inform the end-user of this behavior, the CLI provides informational messages when the user has configured an object that requires a reboot. The following messages are displayed as a result of the configuring such object or objects.

Example 1: Configuring objects that require the device to be rebooted

The following message is displayed every time the user has configured an object that requires the device to be rebooted.

```
[Device Name]>set ipaddr 135.114.73.10  
The following elements require reboot  
ipaddr
```

Example 2: Executing the “exit”, “quit”, or “done” commands when an object that requires reboot has been configured

In addition to the above informational message, the CLI also provides a message as a result of the **exit**, **quit**, or **done** command if changes have been made to objects that require reboot. If you make changes to objects that require reboot and execute the exit command the following message is displayed:

```
[Device Name]>exit<CR> OR quit<CR> OR done<CR>
```

```
Modifications have been made to parameters that require the device to be rebooted. These changes will only take effect after the next reboot.
```

“set” and “show” Command Examples

In general, you will use the CLI **show** Command to view current parameter values and use the CLI **set** Command to change parameter values. As shown in the following examples, parameters may be set individually or all parameters for a given table can be set with a single statement.

Example 1 - Set the Access Point IP Address Parameter

Syntax:

```
[Device Name]>set <parameter name> <parameter value>
```

Example:

```
[Device Name]> set ipaddr 10.0.0.12
```

Result: IP Address will be changed when you reboot the Access Point. The CLI reminds you when rebooting is required for a change to take effect. To reboot immediately, enter **reboot 0** (zero) at the CLI prompt.

Command Line Interface (CLI)

Example 2 - Create a table entry or row

Use 0 (zero) as the index to a table when creating an entry. When creating a table row, only the mandatory table elements are required (comment is usually an optional table element). For optional table elements, the default value is generally applied if you do not specify a value.

Syntax:

```
[Device Name]>set <table name> <table index> <element 1> <value 1> ...
<element n> <value n>
```

Example:

```
[Device Name]> set mgmtipaccesstbl 0 ipaddr 10.0.0.10 ipmask 255.255.0.0
```

Result: A new table entry is created for IP address 10.0.0.10 with a 255.255.0.0 subnet mask.

Example 3 - Modify a table entry or row

Use the index to be modified and the table elements you would like to modify. For example, suppose the IP Access Table has one entry and you wanted to modify the IP address:

```
[Device Name]>set mgmtipaccesstbl 1 ipaddr 10.0.0.11
```

You can also modify several elements in the table entry. Enter the index number and specific table elements you would like to modify. (Hint: Use the search Command to see the elements that belong to the table.)

```
[Device Name]>set mgmtipaccesstbl 1 ipaddr 10.0.0.12 ipmask 255.255.255.248
cmt "First Row"
```

Example 4 - Enable, Disable, or Delete a table entry or row

The following example illustrates how to manage the second entry in a table.

Syntax:

```
[Device Name]>set <Table> index status <enable, disable, delete>
[Device Name]>set <Table> index status <1=enable, 2=disable, 3=delete>
```

Example:

```
[Device Name]>set mgmtipaccesstbl 2 status enable
[Device Name]>set mgmtipaccesstbl 2 status disable
[Device Name]>set mgmtipaccesstbl 2 status delete
[Device Name]>set mgmtipaccesstbl 2 status 2
```

NOTE

You may need to enable a disabled table entry before you can change the entry's elements.

Example 5 - Show the Group Parameters

This example illustrates how to view all elements of a group or table.

Syntax:

```
[Device Name]> show <group name>
```

Example:

```
[Device Name]>show network
```

Result: The CLI displays network group parameters. Note `show network` and `show ip` return the same data.

```
[Device Name]> show network
IP/Network Group Parameters
=====
ipaddr       :      10.0.0.1
ipsubmask    :      255.0.0.0
ipgw         :      10.0.0.1
ipttl        :      64
ipaddrtype   :      static

[Device Name]> show ip
IP/Network Group Parameters
=====
ipaddr       :      10.0.0.1
ipsubmask    :      255.0.0.0
ipgw         :      10.0.0.1
ipttl        :      64
ipaddrtype   :      static

[Device Name]> _
```

Figure A-10 Results of “show network” and “show ip” CLI Commands

Example 6 - Show Individual and Table Parameters

1. View a single parameter.

Syntax:

```
[Device Name]>show <parameter name>
```

Example:

```
[Device Name]> show ipaddr
```

Result: Displays the Access Point IP address.

```
[Device Name]> show ipaddr
ipaddr
10.0.0.1
[Device Name]> _
```

Figure A-11 Result of “show ipaddr” CLI Command

2. View all parameters in a table.

Syntax:

```
[Device Name]> show <table name>
```

Example: [Device Name]> show mgmtipaccesstbl

Result: Displays the IP Access Table and its entries.

Using Tables & User Strings

Working with Tables

Each table element (or parameter) must be specified, as in the example below.

```
[Device Name]>set mgmtipaccesstbl 0 ipaddr 10.0.0.10 ipmask 255.255.0.0
```

Below are the rules for creating, modifying, enabling/disabling, and deleting table entries.

- Creation
 - The table name is required.
 - The table index is required – for table entry/instance creation the index is always zero (0).
 - The order in which the table arguments or objects are entered is not important.
 - Parameters that are not required can be omitted, in which case they will be assigned the default value.

Command Line Interface (CLI)

- Modification
 - The table name is required.
 - The table index is required – to modify the table, “index” must be the index of the entry to be modified.
 - Only the table objects that are to be modified need to be specified. Not all the table objects are required.
 - If multiple table objects are to be modified the order in which they are entered is not important.
 - If the entire table entry is to be modified, all the table objects have to be specified.
- Enabling/Disabling
 - The table name is required.
 - The table index is required – for table enabling/disabling the index should be the index of the entry to be enabled/disabled.
 - The entry’s new state (either “enable” or “disable”) is required.
- Deletion
 - The table name is required.
 - The table index is required – for table deletion the index should be the index of the entry to be deleted.
 - The word “delete” is required.

Using Strings

Since there are several string objects supported by the AP-600, a string delimiter is required for the strings to be interpreted correctly by the command line parser. For this CLI implementation, the single quote or double quote character can be used at the beginning and at the end of the string.

For example:

```
[Device Name]> set sysname Lobby - Does not need quote marks
[Device Name]> set sysname "Front Lobby" - Requires quote marks.
```

The scenarios supported by this CLI are:

"My Desk in Nieuwegein"	Double Quotes
'My Desk in Nieuwegein'	Single Quotes
"My 'Desk' in Nieuwegein"	Single Quotes within Double Quotes
'My "Desk" in Nieuwegein'	Double Quotes within Single Quotes
"Daniel's Desk in Nieuwegein"	One Single Quote within Double Quotes
'Daniel"s Desk in Nieuwegein'	One Double Quote within Single Quotes

The string delimiter does not have to be used for every string object. The single quote or double quote only has to be used for string objects that contain blank space characters. If the string object being used does not contain blank spaces, then the string delimiters, single or double quotes, mentioned in this section are not required.

Configuring the AP-600 using CLI commands

Log into the AP-600 using HyperTerminal

1. Open your terminal emulation program (like HyperTerminal) and set the following connection properties:
 - Com Port: <COM1, COM2, etc., depending on your computer>
 - Baud rate: 9600
 - Data Bits: 8
 - Stop bits: 1
 - Flow Control: None
 - Parity: None
2. Under **File -> Properties -> Settings -> ASCII Setup**, enable the **Send line ends with line feeds** option.
Result: HyperTerminal sends a line return at the end of each line of code.

Command Line Interface (CLI)

3. Enter the CLI password (default is **public**).

⇒ NOTE

Proxim recommends changing your default passwords immediately. To perform this operation using CLI commands, refer to [Change Passwords](#).

Log into the AP-600 using Telnet

The CLI commands can be used to access, configure, and manage the AP-600 using Telnet. Follow these steps:

1. Confirm that your computer's IP address is in the same IP subnet as the AP-600.

⇒ NOTE

If you have not previously configured the Access Point's IP address and do not have a DHCP server on the network, the Access Point will default to an IP address of 169.254.128.132.

2. Go to the DOS command prompt on your computer.
3. Type **telnet <IP Address of the unit>**.
4. Enter the CLI password (default is **public**).

⇒ NOTE

Proxim recommends changing your default passwords immediately. To perform this operation using CLI commands, refer to [Change Passwords](#).

Set Basic Configuration Parameters using CLI Commands

There are a few basic configuration parameters that you may want to setup right away when you receive the AP-600. For example:

- [Set System Name, Location and Contact Information](#)
- [Set Static IP Address for the AP-600](#)
- [Download an AP-600 Configuration File from your TFTP Server](#)
- [Set Network Names for the Wireless Interface](#)
- [Set WEP Encryption for the Wireless Interface](#)
- [Download an AP-600 Configuration File from your TFTP Server](#)
- [Backup your AP-600 Configuration File](#)

Set System Name, Location and Contact Information

```
[Device Name]>set sysname <system name> sysloc <Unit Location>
[Device Name]>set sysctname <Contact Name (person responsible for system)>
[Device Name]>set sysctphone <Contact Phone Number> sysctemail <Contact E-mail address>
[Device Name]>show system
```

```
[Device Name]> show system
System Parameters
=====
sysname           :      Device Name
sysloc            :      System Location
sysctname         :      Contact Name
sysctemail        :      name@Organization.com
sysctphone        :      Contact Phone Number
sysuptime <DD:HH:MM:SS> :      0:11: 6:40
sysoid            :      1.3.6.1.4.1.11898.2.4.6
sysdescr          :      AP v2.1.0 SN-02UT16570004 v2.0.10
syservices        :      2
sysflashupdate   :      0
sysflashbckint   :      120
sysresettodefaults :      0
[Device Name]> _
```

Figure A-12 Result of “show system” CLI Command

Command Line Interface (CLI)

Set Static IP Address for the AP-600

➤ NOTE

The IP Subnet Mask of the AP-600 must match your network's Subnet Mask.

```
[Device Name]>set ipaddrtype static
[Device Name]>set ipaddr <fixed IP address of unit>
[Device Name]>set ipsubmask <IP Mask (default = 255.0.0.0)>
[Device Name]>set ipgw <gateway IP address (default = 169.254.128.133)>
[Device Name]>show network
```

Change Passwords

```
[Device Name]>passwd <Old Password> <New Password> <Confirm Password> (CLI password)
[Device Name]>set httppasswd <New Password> (HTTP interface password)
[Device Name]>set snmprpasswd <New Password> (SNMP read password)
[Device Name]>set snmprpasswd <New Password> (SNMP read/write)
[Device Name]>reboot 0
```

! CAUTION

Proxim strongly urges you to change the default passwords to restrict access to your network devices to authorized personnel. If you lose or forget your password settings, you can always perform the [Reset to Factory Default Procedure](#).

Set Network Names for the Wireless Interface

```
[Device Name]>set wif 3 netname <Network Name (SSID) for wireless interface>
[Device Name]>show wif
```

```
[Device Name]> show wif
Wireless Interface Table
=====
Index                :      3
Network Name         :      My Wireless Network A
Distance Between APs :      large
Interference Robustness :      disable
DTIM Period          :      1
Automatic Channel Selection :      enable
Frequency Channel    :      56
RTS/CTS Medium Reservation :      2347
Multicast Rate       :      2 Mbps
Closed System        :      disable
Load Balancing       :      enable
Medium Density Distribution :      disable
MAC Address          :      00:30:F1:65:09:E9
Supported Data Rates :      6 9 12 18 24 36 48 54
Supported Frequency Channels :      52 56 60 64 36 40 44 48 149 153 157 161
Physical Layer Type  :      OFDM
Regulatory Domain List :      USA (FCC)
Transmit Rate        :      0
TurboMode            :      disable
```

Figure A-13 Results of “show wif” CLI command for an AP-600a

Command Line Interface (CLI)

Set WEP Encryption for the Wireless Interface



CAUTION

Wireless clients must be configured with the same encryption key to be able to communicate with the AP-600. The AP-600 can only support one Key Length (so each of the configured keys must have the same length). The available key sizes vary based on the Access Point's model. See [Security Encryption Key Length Table](#) for more information.

You can set up to four encryption keys. This example describes setting encryption Key 1 on the wireless card in Slot A.

```
[Device Name]>set wifsec 3 encryptstatus enable encryptkey1 <WEP key (number of characters
vary depending on AP model)> encryptkeytx 1
[Device Name]>show wifsec
```

```
[Device Name]> show wifsec
Wireless Security table
=====
Index                :          3
EnableEncryption     :      disable
EncryptionKey1       :      *****
EncryptionKey2       :      *****
EncryptionKey3       :      *****
EncryptionKey4       :      *****
Encryption Key in Use :      key1
Deny Non Encrypted Data :      enable
```

Figure A-14 Result of “show wifsec” CLI Command

Download an AP-600 Configuration File from your TFTP Server

Begin by starting your TFTP program. It must be running and configured to transmit and receive.

```
[Device Name]>set tftpfilename <file name> tftpfiletype config
tftpipaddr <IP address of your TFTP server>
[Device Name]>show tftp (to ensure the filename, file type, and the IP address are correct)
[Device Name]>download *
[Device Name]>reboot 0
```

After following the complete process (above) once, you can download a file of the same name (so long as all the other parameters are the same), with the following command:

```
[Device Name]>download *
```

Backup your AP-600 Configuration File

Begin by starting your TFTP program. It must be running and configured to transmit and receive.

```
[Device Name]>upload <TFTP Server IP address> <tftpfilename (such as “config.sys”)> config
[Device Name]>show tftp (to ensure the filename, file type, and the IP address are correct)
```

After setting the TFTP parameters, you can backup your current file (so long as all the other parameters are the same), with the following command:

```
[Device Name]>upload *
```

Command Line Interface (CLI)

Other Network Settings

There are other configuration settings that you may want to set for the AP-600. Some of them are listed below.

- [Configure the AP-600 as a DHCP Server](#)
- [Configure the DNS Client](#)
- [Maintain Client Connections using Link Integrity](#)
- [Change your Wireless Interface Settings](#)
- [Set Ethernet Speed and Transmission Mode](#)
- [Set Interface Management Services](#)
- [Configure MAC Access Control](#)
- [Set RADIUS Parameters](#)

NOTE

Refer to [Advanced Configuration](#) for more information on these settings.

Configure the AP-600 as a DHCP Server

NOTE

You must have at least one entry in the DHCP Server IP Address Pool Table before you can set the DHCP Server Status to Enable.

```
[Device Name]>set dhcpstatus disable
[Device Name]>set dhcpiptooltbl 0 startipaddr <start ip address>
                    endipaddr <end ip address>
[Device Name]>set dhcpgw <gateway ip address>
[Device Name]>set dhcpridnsipaddr <primary dns ip address>
[Device Name]>set dhcsecdnsipaddr <secondary dns ip address>
[Device Name]>set dhcpstatus enable
[Device Name]>reboot 0
```

CAUTION

Before enabling this feature, confirm that the IP address pools you have configured are valid addresses on the network and do not overlap the addresses assigned by any other DHCP server on the network. Enabling this feature with incorrect address pools will cause problems on your network.

Configure the DNS Client

```
[Device Name]>set dnsstatus enable
[Device Name]>set dnsprsvripaddr <IP address of primary DNS server>
[Device Name]>set dnssecsvripaddr <IP address of secondary DNS server>
[Device Name]>set dnsdomainname <default domain name>
[Device Name]>show dns
```

```
[Device Name]> show dns
DNS Client Group
=====
dnsstatus          :      disable
dnsprsvripaddr    :      0.0.0.0
dnssecsvripaddr   :      0.0.0.0
dnsdomainname     :
```

Figure A-15 Results of “show dns” CLI command

Command Line Interface (CLI)

Maintain Client Connections using Link Integrity

```
[Device Name]>show linkinttbl (this shows the current links)
[Device Name]>set linkinttbl <1-5 (depending on what table row you wish to address)>
                ipaddr <ip address of the host computer you want to check>
[Device Name]>set linkintpollint <the interval between link integrity checks>
[Device Name]>set linkintpollretx <number of times to retransmit before considering
                the link down>
[Device Name]>set linkintstatus enable
[Device Name]>show linkinttbl (confirm new settings)
[Device Name]>reboot 0
```

Change your Wireless Interface Settings

See [Wireless \(AP-600a\)](#) or [Wireless \(AP-600b\)](#) for information on the parameters listed below.

Autochannel Select (ACS)

ACS is enabled by default. Reboot after disabling or enabling ACS.

```
[Device Name]>set wif 3 autochannel <enable/disable>
[Device Name]>reboot 0
```

Enable 2X Turbo Mode (AP-600a Only)

```
[Device Name]>set wif 3 turbo <enable/disable>
[Device Name]>reboot 0
```

Enable/Disable Interference Robustness (AP-600b Only)

```
[Device Name]>set wif 3 interrobust <enable/disable>
```

Enable/Disable Closed System (AP-600b Only)

```
[Device Name]>set wif 3 closedsys <enable/disable>
```

NOTE

When disabled, a client configured with the Network Name "ANY" can connect to the AP-600b. This feature is not currently available for the AP-600a.

Enable/Disable Load Balancing (AP-600b Only)

```
[Device Name]>set wif 3 ldbalance <enable/disable>
```

Enable/Disable Medium Density Distribution (AP-600b Only)

```
[Device Name]>set wif 3 meddendistrib <enable/disable>
```

Command Line Interface (CLI)

Set the Distance Between APs (AP-600b Only)

```
[Device Name]>set wif 3 distaps <large, medium, small, minicell, microcell>
[Device Name]>reboot 0
```

⇒ NOTE

The distance between APs should not be approximated. It is calculated by means of a manual Site Survey, in which an AP-600 is set up and clients are tested throughout the area to determine signal strength and coverage, and local limits such as physical interference are investigated. From these measurements the appropriate cell size and density is determined, and the optimum distance between APs is calculated to suit your particular business requirements.

Set the Multicast Rate (AP-600b Only)

```
[Device Name]>set wif 3 multrate <1,2,5.5,11 (Mbits/sec)>
```

⇒ NOTE

The Distance Between APs **must be set before** the Multicast Rate.

Set Ethernet Speed and Transmission Mode

```
[Device Name]>set etherspeed <value (see below)>
[Device Name]>reboot 0
```

Ethernet Speed and Transmission Mode	Value
10 Mbits/sec - half duplex	10halfduplex
10 Mbits/sec - full duplex	10fullduplex
10 Mbits/sec - auto duplex	10autoduplex
100 Mbits/sec - half duplex	100halfduplex
100 Mbits/sec - full duplex	100fullduplex
Auto Speed - half duplex	autohalfduplex
Auto Speed - auto duplex	autoautoduplex (default)

Set Interface Management Services

Edit Management IP Access Table

```
[Device Name]>set mgmtipaccesstbl <index> ipaddr <IP address> ipmask <subnet mask>
```

Configure Management Ports

```
[Device Name]>set snmpifbitmask <0 - 7 (default is 7 see below)>
[Device Name]>set httpifbitmask <0 - 7 (default is 7 see below)>
[Device Name]>set telifbitmask <0 - 7 (default is 7 see below)>
```

Choose from the following values:

Interface bitmask	Description
0 or 2 = disable (all interfaces)	All management channels disabled
1 or 3 = Ethernet only	Ethernet only enabled
4 or 6 = Wireless only	Wireless only enabled
5 or 7 = all interfaces	All management channels enabled

Command Line Interface (CLI)

Set Communication Ports

```
[Device Name]>set httpport <HTTP port number (default is 80)>
[Device Name]>set telport <Telnet port number (default is 23)>
```

Set Telnet Session Timeouts

```
[Device Name]>set tellogintout <time in seconds between 1 and 300 (default is 30)>
[Device Name]>set telsessionout <time in seconds between 1 and 36000 (default is 900)>
```

Configure Serial Port Interface

➤ NOTE

To avoid unexpected performance issues, leave Flow Control at the default setting (none) unless you are sure what this setting should be.

```
[Device Name]>set serbaudrate <2400, 4800, 9600, 19200, 38400, 57600>
[Device Name]>set serflowctrl <none, xon/xoff>
[Device Name]>show serial
```

```
[Device Name]> show serial
Serial Interface Group Parameters
=====
serbaudrate      :      9600
serdatabits      :          8
serparity        :      none
serstopbits     :          1
serflowctrl     :      none
```

Figure A-16 Result of “show serial” CLI Command

Configure Syslog

```
[Device Name]>set syslogpriority <1-7 (default is 6)>
[Device Name]>set syslogstatus <enable/disable>
```

Configure Intra BSS

```
[Device Name]>set intrabssoptype <passthru (default)/block>
```

Configure MAC Access Control

Setup MAC (Address) Access Control

```
[Device Name]>set macaclstatus enable
[Device Name]>set macacloptype <passthru, block>
[Device Name]>reboot 0
```

Add an Entry to the MAC Access Control Table

```
[Device Name]>set macacltbl <index> macaddr <MAC Address> status enable
[Device Name]>show macacltbl
```

Disable or Delete an Entry in the MAC Access Control Table

```
[Device Name]>set macacltbl <index> status <disable/delete>
[Device Name]>show macacltbl
```

➤ NOTE

For larger networks that include multiple Access Points, you may prefer to maintain this list on a centralized location using the RADIUS parameters (see [Set RADIUS Parameters](#)).

Command Line Interface (CLI)

Configure 802.1x Authentication

```
[Device Name]>set secconfig <none, 802.1x, mixed>
[Device Name]>set secenckeylentbl 3 enckeylen <64bits, 128bits>
[Device Name]>set secrekeyint <60 - 65535 seconds; default is 900 sec>
[Device Name]>reboot 0
```

➡ NOTE

If you set Security to 802.1x or Mixed, you also need to configure the RADIUS parameters. If you set Security to Mixed, you also need to configure WEP Encryption settings. See [802.1x](#) for details.

Set RADIUS Parameters

Configure RADIUS Authentication server

```
[Device Name]>set radiustbl <index> status enable seraddrfmt <ipaddr or name>
                    ipaddr <RADIUS IP address or name> port <user defined>
                    ssecret <user defined> responsetm <1 to 4 seconds>
                    maxretx <1 to 10 times>
[Device Name]>show radiustbl
```

```
[Device Name]> show radiustbl
RADIUS Authentication Group Table
=====
Index          :          1
RADIUS Auth Server Status:  disable
IP Address/Host Name  :  0.0.0.0
Authentication Port   :  1812
Response Time        :  3
Shared Secret        :  *****
Server Addressing Format:  ipaddr
Maximum Retransmission :  3

Index          :          2
RADIUS Auth Server Status:  disable
IP Address/Host Name  :  0.0.0.0
Authentication Port   :  1812
Response Time        :  3
Shared Secret        :  *****
Server Addressing Format:  ipaddr
Maximum Retransmission :  3
```

Figure A-17 Results of "show radiustbl" CLI command

Enable RADIUS MAC Access Control

```
[Device Name]>set radmacaccctrl enable
[Device Name]>reboot 0
```

Set MAC Address Format Type

```
[Device Name]>set radmacaddrformat <dashdelimited, colondelimited, singledashdelimited,
                    nodelimiter>
```

Set Authorization Lifetime

```
[Device Name]>set radauthlifetm <900-43200 seconds; default is 900>
```

Enable RADIUS Accounting

```
[Device Name]>set radaccstatus enable
[Device Name]>set radaccinactivetmr <inactivity timer in minutes>
[Device Name]>show radius
```

Command Line Interface (CLI)

```
[Device Name] > show radius
RADIUS Group
=====
RADIUS Authentication
=====
radcliusraddr      :      0
radmacacctrl       :      disable
radauthlifetm      :      900
radmacaddrformat    :      dashdelimited

RADIUS Accounting
=====
radaccstatus        :      disable
radaccinactivetmr  :      5
```

Figure A-18 Result of “show radius” CLI Command

Configure RADIUS Accounting server

```
[Device Name] > set radacctbl <index> status <enable> seraddrfmt <ipaddr or name> ipaddr
                    <RADIUS IP address or name> port <user defined> ssecret <user defined>
                    responsetm <1 to 4 seconds> maxretx <1 to 10 times>
[Device Name] > show radacctbl
```

```
[Device Name] > show radacctbl
RADIUS Accounting Group Table
=====
Index      :      1
RADIUS Acc Server Status:  disable
IP Address/Host Name  :  0.0.0.0
Accounting Port       :  1813
Response Time        :  3
Shared Secret         :  *****
Server Addressing Format:  ipaddr
Maximum Retransmission :  3

Index      :      2
RADIUS Acc Server Status:  disable
IP Address/Host Name  :  0.0.0.0
Accounting Port       :  1813
Response Time        :  3
Shared Secret         :  *****
Server Addressing Format:  ipaddr
Maximum Retransmission :  3
```

Figure A-19 Results of “show radacctbl” CLI command

CLI Monitoring Parameters

Using the **show** command with the following table parameters will display operating statistics for the AP-600 (these are the same statistics that are described in [Monitor Information](#) for the HTTP Web interface).

- **staticmp**: Displays the ICMP Statistics.
- **statarptbl**: Displays the IP ARP Table Statistics.
- **statbridgetbl**: Displays the Learn Table.
- **statiapp**: Displays the IAPP Statistics.
- **statradius**: Displays the RADIUS Authentication Statistics.
- **statif**: Displays information and statistics about the Ethernet and wireless interfaces.
- **stat802.11**: Displays additional statistics for the wireless interfaces.
- **statethernet**: Displays additional statistics for the Ethernet interface.

Parameter Tables

Objects contain groups that contain both parameters and parameter tables. Use the following Tables to configure the Access Point. Columns used on the tables include:

- Name - Parameter, Group, or Table Name
- Type - Data type
- Values - Value range, and default value, if any
- Access = access type, R = Read Only (show), RW = Read-Write (can be "set"), W = Write Only
- CLI Parameter - Parameter name as used in the Access Point

Access Point network objects are associated with Groups. The network objects are listed below and associated parameters are described in the following Parameter Tables:

- [System Parameters](#) - Access Point system information
 - [Inventory Management Information](#) - Hardware, firmware, and software version information
- [Network Parameters](#) - IP and Network Settings
 - [IP Configuration Parameters](#) - Configure the Access Point's IP settings
 - [DNS Client for RADIUS Name Resolution](#) - Configure the Access Point as a DNS client
 - [DHCP Server Parameters](#) - Enable or disable dynamic host configuration
 - [Link Integrity Parameters](#) - Monitor link status
- [Interface Parameters](#) - Configure Wireless and Ethernet settings
 - [Wireless Interface Parameters](#)
 - [Wireless Distribution System \(WDS\) Parameters \(AP-600b Only\)](#) - Configure the WDS partnerships
 - [Ethernet Interface Parameters](#) - Set the speed and duplex of the Ethernet port
- [Management Parameters](#) - Control access to the AP-600's management interfaces
 - [SNMP Parameters](#) - Set read and read/write passwords
 - [HTTP \(web browser\) Parameters](#) - Set up the graphical web browser interface
 - [Telnet Parameters](#) - Telnet Port setup
 - [Serial Port Parameters](#) - Serial Port setup
 - [TFTP Server Parameters](#) - Set up for file transfers; specify IP Address, file name, and file type
 - [IP Access Table Parameters](#) - Configure range of IP addresses that can access the AP-600
- [Filtering Parameters](#)
 - [Ethernet Protocol Filtering Parameters](#) - Control network traffic based on protocol type
 - [Static MAC Address Filter Table](#) - Enable and disable specific addresses
 - [Proxy ARP Parameters](#) - Enable or disable proxy ARP for wireless clients
 - [IP ARP Filtering Parameters](#) - Control which ARP messages are sent to wireless clients based on IP settings
 - [Broadcast Filtering Table](#) - Control the type of broadcast packets forwarded to the wireless network
 - [TCP/UDP Port Filtering](#) - Filter IP packets based on TCP/UDP port
- [Alarms Parameters](#)
 - [SNMP Table Host Table Parameters](#) - Enter the list of IP addresses that will receive alarms from the AP-600
 - [Syslog Parameters](#) - Configure the AP-600 to send Syslog information to network servers
- [Bridge Parameters](#)
 - [Spanning Tree Parameters](#) - Used to help prevent network loops
 - [Storm Threshold Parameters](#) - Set threshold for number of broadcast packets
 - [Intra BSS Subscriber Blocking](#) - Enable or disable peer to peer traffic on the same AP
 - [Packet Forwarding Parameters](#) - Redirect traffic from wireless clients to a specified MAC address
- [Security Parameters](#) - Access Point security settings
 - [Wireless Interface Security Parameters](#) - Configure WEP encryption settings
 - [MAC Access Control Parameter](#) - Control wireless access based on MAC address
- [RADIUS Parameters](#)
 - [Primary and Backup RADIUS Server Table Parameters](#) - RADIUS Authentication and Accounting information
- [Other Parameters](#)
 - [IAPP Parameters](#) - Enable or disable the Inter-Access Point Protocol
 - [SpectraLink VoIP Parameters \(AP-600b Only\)](#) - Enable or disable SpectraLink Voice over IP feature

Command Line Interface (CLI)

System Parameters

Name	Type	Values	Access	CLI Parameter
System	Group	N/A	R	system
Name	DisplayString	User Defined	RW	sysname
Location	DisplayString	User Defined	RW	sysloc
Contact Name	DisplayString	User Defined	RW	sysctname
Contact E-mail	DisplayString	User Defined	RW	sysctemail
Contact Phone	DisplayString	User Defined max 254 characters	RW	sysctphone
FLASH Backup Interval	Integer	0 - 65535 seconds	RW	sysflashbckint
Flash Update		0 1	RW	sysflashupdate
System OID	DisplayString	N/A	R	sysoid
Descriptor	DisplayString	System Name, flash version, S/N, bootloader version	R	sysdescr
Up Time	Integer	dd:hh:mm:ss dd – days hh – hours mm – minutes ss – seconds	R	sysuptime
Emergency Restore to defaults		Resets all parameters to default factory values	RW	sysresettodefaults Note: You must enter the following command twice to reset to defaults: set sysresettodefaults 1

Inventory Management Information

Name	Type	Values	Access	CLI Parameter
System Inventory Management	Subgroup	N/A	R	sysinvmgmt
Component Table	Subgroup	N/A	R	sysinvmgmtcptbl
Component Interface Table	Subgroup	N/A	R	sysinvmgmtcpiptbl

⇒ NOTE

The inventory management commands display advanced information about the AP-600's installed components. You may be asked to report this information to a representative if you contact customer support.

Network Parameters

IP Configuration Parameters

Name	Type	Values	Access	CLI Parameter
Network	Group	N/A	R	network
IP Configuration	Group	N/A	R	ip (Note: The network and ip parameters display the same information)
IP Address	IpAddress	User Defined	RW	ipaddr
IP Mask	IpAddress	User Defined	RW	ipmask
Default Router IP Address	IpAddress	User Defined	RW	ipgw
Default TTL	Integer	User Defined (seconds) 64 (default)	RW	ipttl
Address Type	Integer	static dynamic (default)	RW	ipaddrtype

⇒ NOTE

The IP Address Assignment Type (ipaddrtype) must be set to static before the IP Address (ipaddr), IP Mask (ipmask) or Default Gateway IP Address (ipgw) values can be entered.

Command Line Interface (CLI)

DNS Client for RADIUS Name Resolution

Name	Type	Values	Access	CLI Parameter
DNS Client	Group	N/A	R	dns
DNS Client status	Integer	enable disable (default)	RW	dnsstatus
Primary DNS Server IP Address	IpAddress	User Defined	RW	dnspridnsipaddr
Secondary DNS Server IP Address	IpAddress	User Defined	RW	dnssecdnsipaddr
Default Domain Name	Integer32	User Defined (up to 254 characters)	RW	dnsdomainname

DHCP Server Parameters

Name	Type	Values	Access	CLI Parameter
DHCP Server	Group	N/A	R	dhcp
DHCP Server Status	Integer	enable (1) (default) disable (2) delete (3)	RW	dhcpstatus
Gateway IP Address	IpAddress	User Defined	RW	dhcpgw
Primary DNS IP Address	IpAddress	User Defined	RW	dhcppridnsipaddr
Secondary DNS IP Address	IpAddress	User Defined	RW	dhcpsecdnsipaddr
Number of IP Pool Table Entries	Integer32	N/A	R	dhcpiptooltblent

⇒ NOTE

The DHCP Server (dhcpstatus) can only be enabled after a DHCP IP Pool table entry has been created.

DHCP Server table for IP pools

Name	Type	Values	Access	CLI Parameter
DHCP Server IP Address Pool Table	Table	N/A	R	dhcpiptooltbl
Table Index	Integer	User Defined	N/A	index
Start IP Address	IpAddress	User Defined	RW	startipaddr
End IP Address	IpAddress	User Defined	RW	endipaddr
Width	Integer	User Defined	RW	width
Default Lease Time (optional)	Integer32	> 0 86400 sec (default)	RW	defleasetm
Maximum Lease Time (optional)	Integer32	> 0 86400 sec (default)	RW	maxleasetm
Comment (optional)	DisplayString	User Defined	RW	cmt
Status (optional)	Integer	enable (1) disable (2) delete (3)	RW	status

⇒ NOTE

Set either End IP Address or Width (but not both) when creating an IP address pool.

Command Line Interface (CLI)

Link Integrity Parameters

Name	Type	Values	Access	CLI Parameter
Link Integrity	Group	N/A	R	linkint
Link Integrity Status	Integer	enable disable (default)	RW	linkintstatus
Link Integrity Poll Interval	Integer	500 - 15000 ms (in increments of 500ms) 500 ms (default)	RW	linkintpollint
Link Integrity Poll Retransmissions	Integer	0 - 255 5 (default)	RW	linkintpollretx

Link Integrity IP Target Table

Name	Type	Values	Access	CLI Parameter
Link Integrity IP Target Table	Table	N/A	R	linkinttbl
Table Index	Integer	1-5	N/A	index
Target IP Address	IpAddress	User Defined	RW	ipaddr
Comment (optional)	DisplayString	User Defined (up to 254 characters)	RW	cmt
Status (optional)	Integer	enable disable (default) delete	RW	status

Interface Parameters

Wireless Interface Parameters

The wireless interface group parameter is **wif**. The interface uses table index 3.

Common Parameters to AP-600a and AP-600b

Name	Type	Values	Access	CLI Parameter
Wireless Interfaces	Group	N/A	R	wif
Table Index	Integer	3	R	index
Network Name	DisplayString	1 – 31 characters My Wireless Network A (default)	RW	netname
Auto Channel Select (ACS)	Integer	enable (default) disable	RW	autochannel
DTIM Period	Integer	1 – 65535 1 = default	RW	dtimperiod
RTS/CTS Medium Reservation	Integer	0 – 2347 Default is 2347 (off)	RW	medres
MAC Address	PhyAddress	12 hex digits	R	macaddr
Supported Frequency Channels	Octet String	Depends on Regulatory Domain	R	suppchannels



NOTE

For AP-600a units in Europe, Auto Channel Select is a read-only parameter; it is always enabled.

Command Line Interface (CLI)

AP-600a Only Parameters

Name	Type	Values	Access	CLI Parameter
Operating Frequency Channel	Integer	Varies by regulatory domain and country. See 802.11a Channel Frequencies for the AP-600a	RW	channel
2X Turbo Mode (not available in all countries)	Integer	enable disable (default)	RW	turbo
Supported Data Rates	Octet String	See Transmit Rate , below	R	suppdatarates
Transmit Rate	Integer32	Reported in 500 Kb/sec intervals: 0 - Auto Fallback (default) 12 (6 Mbits/sec) 18 (9 Mbits/sec) 24 (12 Mbits/sec) 36 (18 Mbits/sec) 48 (24 Mbits/sec) 72 (36 Mbits/sec) 96 (48 Mbits/sec) 108 (54 Mbits/sec) For Turbo mode (not available in all countries): 0 - Auto Fallback (default) 24 (12 Mbits/sec) 38 (18 Mbits/sec) 48 (24 Mbits/sec) 72 (36 Mbits/sec) 96 (48 Mbits/sec) 144 (72 Mbits/sec) 192 (96 Mbits/sec) 216 (108 Mbits/sec)	RW	txrate
Physical Layer Type	Integer	ofdm (orthogonal frequency division multiplexing) for 802.11a	R	phytype
Regulatory Domain List	DisplayString	FCC (5.15-5.35 GHz, 5.725-5.850 GHz) ETSI (5.15-5.25 GHz only) ETSI (5.15-5.35 GHz) MMK (5.15-5.25 GHz) Singapore (5.15-2.25 GHz, 5.725-5.850 GHz)	R	regdomain

AP-600b Only Parameters

Name	Type	Values	Access	CLI Parameter
Distance between APs	Integer	large (default) medium small minicell microcell	RW	distaps
Interference Robustness	Integer	enable (default) disable	RW	interrobust
Operating Frequency Channel	Integer	1 - 14; available channels vary by regulatory domain/country; see 802.11b Channel Frequencies for the AP-600b	RW	channel

Command Line Interface (CLI)

Name	Type	Values	Access	CLI Parameter
Multicast Rate	Integer	1 Mbits/sec (1) 2 Mbits/sec (2) (default) 5.5 Mbits/sec (3) 11 Mbits/sec (4)	RW	multirate
Closed Wireless System	Integer	enable disable (default)	RW	closedsys
Load Balancing	Integer	enable (default) disable	RW	ldbalance
Medium Distribution	Integer	enable (default) disable	RW	meddendistrib
MAC Address	PhyAddress	12 hex digits	R	macaddr
Supported Data Rates	Octet String	Reported in 500 Kb/sec intervals: 2 (1 Mbits/sec) 4 (2 Mbits/sec) (default) 11 (5.5 Mbits/sec) 22 (11 Mbits/sec)	R	suppdatarates
Transmit Rate	Integer32	Reported in 500 Kb/sec intervals: 0 (auto fallback - default) 2 (1 Mbits/sec) 4 (2 Mbits/sec) 11 (5.5 Mbits/sec) 22 (11 Mbits/sec)	RW	txrate
Supported Frequency Channels	Octet String	Depends on Regulatory Domain	R	suppchannels
Physical Layer Type	Integer	dsSS (direct sequence spread spectrum) for 802.11b	R	phytype
Regulatory Domain List	DisplayString	U.S./Canada -- FCC Europe -- ETSI Japan -- MKK	R	regdomain

NOTE

There is an inter-dependent relationship between the Distance between APs and the Multicast Rate. In general, larger systems operate a lower average transmit rates.

Distance between APs	Multicast Rate
Large	1 and 2 Mbits/sec
Medium	1, 2, and 5.5 Mbits/sec
Small	1, 2, 5.5 and 11 Mbits/sec
Minicell	1, 2, 5.5 and 11 Mbits/sec
Microcell	1, 2, 5.5 and 11 Mbits/sec

Wireless Distribution System (WDS) Parameters (AP-600b Only)

NOTE

At this time, WDS is not available for the AP-600a.

Name	Type	Values	Access	CLI Parameter
WDS Table	Table	N/A	R	wdstbl
Port Index	Integer	3.1 - 3.6 (Wireless)	R	portindex
Status	Integer	enable, disable	RW	status
Partner MAC Address	PhyAddress	User Defined	RW	partnermacaddr

Command Line Interface (CLI)

Ethernet Interface Parameters

Name	Type	Values	Access	CLI Parameter
Ethernet Interface	Group	N/A	R	ethernet
Speed	Integer	10halfduplex 10fullduplex 10autoduplex 100halfduplex 100fullduplex autohalfduplex autoautoduplex (default)	RW	etherspeed
MAC Address	PhyAddress	N/A	R	ethermacaddr

Management Parameters

SNMP Parameters

Name	Type	Values	Access	CLI Parameter
SNMP	Group	N/A	R	snmp
SNMP Management Interface Bitmask	Interface Bitmask	0 or 2 - no interfaces (disable) 1 or 3 - Ethernet 4 or 6 - Wireless 5 or 7 - all interfaces (default is 7)	RW	snmpifbitmask
Read Password	DisplayString	User Defined public (default) max 63 characters	W	snmprpasswd
Read/Write Password	DisplayString	User Defined public (default) max 63 characters	W	snmprwpasswd

HTTP (web browser) Parameters

Name	Type	Values	Access	CLI Parameter
HTTP	Group	N/A	R	http
HTTP Management Interface Bitmask	Interface Bitmask	0 or 2 - no interfaces (disable) 1 or 3 - Ethernet 4 or 6 - Wireless 5 or 7 - all interfaces (default is 7)	RW	httpifbitmask
HTTP Password	DisplayString	User Defined max 64 characters	W	httppasswd
HTTP Port	Integer	User Defined Default = 80	RW	httpport
Help Link	DisplayString	User Defined	RW	httphelplink

NOTE

The default path for the Help files is *C:\Program Files\ORiNOCO\AP600\HTML\index.htm*. The ORiNOCO AP-600 Help information is available in English, French, German, Italian, Spanish, and Japanese.

Command Line Interface (CLI)

Telnet Parameters

Name	Type	Values	Access	CLI Parameter
Telnet	Group	N/A	R	telnet
Telnet Management Interface Bitmask	Interface Bitmask	0 or 2 - no interfaces (disable) 1 or 3 - Ethernet 4 or 6 - Wireless 5 or 7 - all interfaces (default is 7)	RW	telifbitmask
Telnet Port	Integer	User Defined 23 (default)	RW	telport
Telnet Login Inactivity Time-out	Integer	1 – 300 seconds 30 sec (default)	RW	tellointout
Telnet Session Idle Time-out	Integer	1 - 900 seconds 900 sec (default)	RW	telsessiontout

Serial Port Parameters

Name	Type	Values	Access	CLI Parameter
Serial	Group	N/A	R	serial
Baud Rate	Integer	2400, 4800, 9600 (default), 19200, 38400, 57600	RW	serbaudrate
Data Bits	Integer	8	R	serdatabits
Parity	Integer	none	R	serparity
Stop Bits	Integer	1	R	serstopbits
Flow Control	Value	none (default) xon/xoff	RW	serflowctrl

TFTP Server Parameters

These parameters relate to upload and download commands.

When a user executes an upload and/or download Command, the specified arguments are stored in TFTP parameters for future use. If nothing is specified in the command line when issuing subsequent upload and/or download commands, the stored arguments are used.

Name	Type	Values	Access	CLI Parameter
TFTP	Group	N/A	R	tftp
TFTP Server IP Address	IpAddress	User Defined	RW	tftpipaddr
TFTP File Name	DisplayString	User Defined	RW	tftpfilename
TFTP File Type	Integer	img config bootloader	RW	tftpfiletype

Command Line Interface (CLI)

IP Access Table Parameters

When creating table entries, you may either specify the argument name followed by argument value or simply entering the argument value. When only the argument value is specified, then enter the values in the order depicted by the following table. CLI applies default values to the omitted arguments. Due to the nature of the information, the only argument that can be omitted is the “comment” argument.

Name	Type	Values	Access	CLI Parameter
IP Access Table	Table	N/A	R	mgmtipaccesstbl
Table Index	Integer	User Defined	N/A	index
IP Address	IpAddress	User Defined	RW	ipaddr
IP Mask	IpAddress	User Defined	RW	ipmask
Comment (optional)	DisplayString	User Defined	RW	cmt
Status (optional)	Integer	enable (default) disable delete	RW	status

Filtering Parameters

Ethernet Protocol Filtering Parameters

Name	Type	Values	Access	CLI Parameter
Ethernet Filtering	Group	N/A	R	etherflt
Filtering Interface Bitmask	Interface Bitmask	0 or 2 - no interfaces (disable) 1 or 3 - Ethernet 4 or 6 - Wireless 5 or 7 - all interfaces (default is 7)	RW	etherfltifbitmask
Operation Type		passthru block	RW	etherfltoptype

Ethernet Filtering Table

Identify the different filters by using the table index.

Name	Type	Values	Access	CLI Parameter
Ethernet Filtering Table	Table	N/A	R	etherflttbl
Table Index	N/A	N/A	R	index
Protocol Number	Octet String	N/A	RW	protonumber
Protocol Name (optional)	DisplayString		RW	protoname
Filter Comment	DisplayString	2- 31 characters	RW	cmt
Status (optional)	Integer	enable (1) disable (2) delete (3)	RW	status

➡ NOTE

The filter Operation Type (passthru or block) applies **only** to the protocol filters that are **enabled** in this table.

Command Line Interface (CLI)

Static MAC Address Filter Table

Name	Type	Values	Access	CLI Parameter
Static MAC Address Filter Table	Table	N/A	R	staticmactbl
Table Index	N/A	N/A	R	index
Static MAC Address on Wired Network	PhysAddress	User Defined	RW	wiredmacaddr
Static MAC Address Mask on Wired Network	PhysAddress	User Defined	RW	wiredmask
Static MAC Address on Wireless Network	PhysAddress	User Defined	RW	wirelessmacaddr
Static MAC Address Mask on Wireless Network	PhysAddress	User Defined	RW	wirelessmask
Comment (optional)	DisplayString	max 255 characters	RW	cmt
Status (optional)	Integer	enable (default) disable delete	RW	status

Proxy ARP Parameters

Name	Type	Values	Access	CLI Parameter
Proxy ARP	Group	N/A	R	parp
Status	Integer	enable disable (default)	RW	parpstatus

IP ARP Filtering Parameters

Name	Type	Values	Access	CLI Parameter
IP ARP Filtering	Group	N/A	R	iparp
Status	Integer	enable disable (default)	RW	iparpfltstatus
IP Address	IpAddress	User Defined	RW	iparpfltaddr
Subnet Mask	IpAddress	User Defined	RW	iparpfltsubmask

Broadcast Filtering Table

Name	Type	Values	Access	CLI Parameter
Broadcast Filtering Table	Table	N/A	R	broadcastflttbl
Index	Integer	1-5	N/A	index
Protocol Name	DisplayString	N/A	R	protoname
Direction	Integer	ethertowireless wirelesstoether both (default)	RW	direction
Status	Integer	enable disable (default)	RW	status

Command Line Interface (CLI)

TCP/UDP Port Filtering

The following parameters are used to enable/disable the Port filter feature.

Name	Type	Values	Access	CLI
Port Filtering	Group	N/A	R	portflt
Port Filter Status	Integer	enable (default) disable	RW	portfltstatus

TCP/UDP Port Filtering Table

The following parameters are used to configure TCP/UDP Port filters.

Name	Type	Values	Access	CLI
Port Filtering Table	Table	N/A	R	portfltbl
Table Index	N/A	User Defined (there are also 4 pre-defined indices, see Port Number below for more information)	R	index
Port Type	Octet String	TCP UDP TCP/UDP	RW	porttype
Port Number	Octet String	User Defined (there are also 4 pre-defined protocols: Index 1: NetBios Name Service – 137, Index 2: NetBios Datagram Service – 138, Index 3: NetBios Session Service – 139, Index 4: SNMP Service – 161)	RW	portnum
Protocol Name	DisplayString	User Defined (there are also 4 pre-defined protocols, see Port Number above)	RW	protoname
Interface Bitmask	Integer32	0 or 2 - no interfaces (disable) 1 or 3 - Ethernet 4 or 6 - Wireless 5 or 7 - all interfaces (default is 7)	RW	ifbitmask
Status (optional)	Integer	enable (default for new entries) disable (default for pre-defined entries) delete	RW	status

Command Line Interface (CLI)

Alarms Parameters

SNMP Table Host Table Parameters

When creating table entries, you may either specifying the argument name followed by argument value. CLI applies default values to the omitted arguments. Due to the nature of the information, the only argument that can be omitted is the “comment” argument.

Name	Type	Values	Access	CLI Parameter
SNMP Trap Host Table	Table	N/A	R	snmptraphosttbl
Table Index	Integer	User Defined	N/A	index
IP Address	IpAddress	User Defined	RW	ipaddr
Password	DisplayString	User Defined (up to 64 characters)	W	passwd
Comment (optional)	DisplayString	User Defined (up to 254 characters)	RW	cmt
Status (optional)	Integer	enable (default) disable delete	RW	status

Syslog Parameters

The following parameters configure the Syslog settings.

Name	Type	Values	Access	CLI
Syslog	Group	N/A	R	syslog
Syslog Status	Integer	enable disable (default)	RW	syslogstatus
Syslog Port	Octet String	514	R	syslogport
Syslog Lowest Priority Logged	Integer	1 – 7 1 = LOG_ALERT 2 = LOG_CRIT 3 = LOG_ERR 4 = LOG_WARNING 5 = LOG_NOTICE 6 = LOG_INFO (default) 7 = LOG_DEBUG	RW	syslogpriority
Heartbeat Status	Integer	enable (1) disable (2) (default)	RW	heartbeatstatus
Heartbeat Interval (seconds)	Integer	1 – 604800 seconds; 900 sec. (default)	RW	heartbeatinterval

⇒ NOTE

The Heartbeat parameters are advanced settings not available via the HTTP interface. When Heartbeat is enabled, the AP-600 periodically sends a message to the Syslog server to indicate that it is active. The frequency with which the heartbeat message is sent depends upon the setting of the Heartbeat Interval.

Syslog Host Table

The table described below configures the Syslog hosts that will receive message from the AP-600. You can configure up to ten Syslog hosts.

Name	Type	Values	Access	CLI Parameter
Syslog Host Table	Table	N/A	R	sysloghosttbl
Table Index	Integer	1 – 10	N/A	index
IP Address	IpAddress	User Defined	RW	ipaddr
Comment (optional)	DisplayString	User Defined	RW	cmt
Status (optional)	Integer	enable disable delete	RW	status

Command Line Interface (CLI)

Bridge Parameters

Spanning Tree Parameters

Name	Type	Values	Access	CLI Parameter
Spanning Tree	Group	N/A	R	stp
Spanning Tree Status	Integer	enable disable (default)	RW	stpstatus
Bridge Priority	Integer	0 – 65535 32768 (default)	RW	stp priority
Maximum Age	Integer	600 – 4000 (in 0.01 sec intervals; i.e., 6 to 40 seconds) 2000 (default)	RW	stp maxage
Hello Time	Integer	100 – 1000 (in 0.01 sec intervals; i.e., 1 to 10 seconds) 200 (default)	RW	stp hello time
Forward Delay	Integer	400 – 3000 (in 0.01 sec intervals; i.e., 4 to 30 seconds) 1500 (default)	RW	stp forward delay

Spanning Tree Priority and Path Cost Table

Name	Type	Values	Access	CLI Parameter
Spanning Tree Table	Table	N/A	R	stpbl
Table Index (Port)	N/A	1 – 15	R	index
Priority	Integer	0 – 255 128 (default)	RW	priority
Path Cost	Integer	1 – 65535 100 (default)	RW	pathcost
State	Integer	disable blocking listening learning forwarding broken	R	state
Status	Integer	enable disable	RW	status

Storm Threshold Parameters

Name	Type	Values	Access	CLI Parameter
Storm Threshold	Group	N/A	N/A	stmthres
Broadcast Threshold	Integer	0 – 255 packets/sec (default is 0)	RW	stmbrdthres
Multicast Threshold	Integer	0 – 255 packets/sec (default is 0)	RW	stm multithres

Storm Threshold Table

Name	Type	Values	Access	CLI Parameter
Storm Threshold Table	Table	N/A	R	stmthresbl
Table Index	Integer	1 = Ethernet 3 = Wireless	R	index
Broadcast Threshold	Integer	0 – 255 packets/sec (default is 0)	RW	bcast
Multicast Threshold	Integer	0 – 255 packets/sec (default is 0)	RW	mcast

Command Line Interface (CLI)

Intra BSS Subscriber Blocking

The following parameters control the Intra BSS traffic feature, which prevent wireless clients that are associated with the same AP-600 from communicating with each other:

Name	Type	Values	Access	CLI
Intra BSS Traffic	Group	N/A	R	intrabss
Intra BSS Traffic Operation	Integer	passthru (default) block	RW	intrabssoptype

Packet Forwarding Parameters

The following parameters control the Packet Forwarding feature, which redirects wireless traffic to a specific MAC address:

Name	Type	Values	Access	CLI
Packet Forwarding MAC Address	Group	N/A	R	pktfwd
Packet Forwarding MAC Address	MacAddress	User Defined	RW	pktfwdmacaddr
Packet Forwarding Status	Integer	enable disable (default)	RW	pktfwdstatus
Packet Forwarding Interface Port	Integer	0 (any) (default) 1 (Ethernet) 2 (WDS 1) 3 (WDS 2) 4 (WDS 3) 5 (WDS 4) 6 (WDS 5) 7 (WDS 6)	RW	pktfwdif

⇒ NOTE

The Wireless Distribution System (WDS) feature is not available for the AP-600a at this time.

Security Parameters

Name	Type	Values	Access	CLI Parameter
Security	Group	N/A	R	security
Configuration Mode	Integer	none (default), 802.1x, mixed	RW	secconfig
Re-keying Interval	Integer	60 – 65535 seconds default is 900 sec	RW	secrekeyint

Wireless Interface Security Parameters

The following table details the WEP encryption parameters for the AP-600 (both the AP-600a and the AP-600b).

Name	Type	Values	Access	CLI Parameter
Wireless Interface Security	Group		R	wifsec
Encryption Status	Integer	enable, disable (default)	RW	encryptstatus
Index	Integer	3	R	index
Encryption Key 1	DisplayString	User Defined	W	encryptkey1
Encryption Key 2	DisplayString	User Defined	W	encryptkey2
Encryption Key 3	DisplayString	User Defined	W	encryptkey3
Encryption Key 4	DisplayString	User Defined	W	encryptkey4
Deny non-encrypted Data	Integer	enable (default), disable	RW	encryptdeny
Data Transmission Encryption Key	Integer	1 (default), 2, 3, 4	RW	encryptkeytx

⇒ NOTE

See [WEP Encryption](#) for information on the supported WEP Key lengths.

Command Line Interface (CLI)

Security Encryption Key Length Table

The following table details how to set the Encryption Key Length for the wireless interfaces.

Name	Type	Values	Access	CLI Parameter
Security Encryption Key Length Table	Table	N/A	R	secenckeylentbl
Index	Integer	3	N/A	index
Encryption Key Length	Integer	64bits 128bits	RW	enckeylen

MAC Access Control Parameter

Name	Type	Values	Access	CLI Parameter
MAC Address Control	Group	N/A	R	macacl
Status	Integer	enable disable (default)	RW	macaclstatus
Operation Type	Integer	passthru (default) block	RW	macacloptype

MAC Access Control Table

Name	Type	Values	Access	CLI Parameter
MAC Address Control Table	Table	N/A	R	macactbl
Table Index	N/A	N/A	R	index
MAC Address	PhysAddress	User Defined	RW	macaddr
Comment (optional)	DisplayString	User Defined max 254 characters	RW	cmt
Status (optional)	Integer	enable (default) disable	RW	status

RADIUS Parameters

Primary and Backup RADIUS Server Table Parameters

ORiNOCO devices that use RADIUS authentication and/or accounting support both primary and backup RADIUS servers. The configuration parameters and statistics are the same for both primary and backup servers. The CLI differentiates the primary and backup RADIUS parameters by using the table index.

General RADIUS Parameters

Name	Type	Values	Access	CLI Parameter
RADIUS	Group	N/A	R	radius
MAC Access Control Status	Integer	enable disable (disable)	R	radmacacctrl
Authorization Lifetime	Integer32	900 – 43200 seconds 900 sec. (default)	RW	radauthlifetm
MAC Address Format	Integer	dashdelimited (default) colondelimited singledashdelimited no delimiter	RW	radmacaddrformat
RADIUS Accounting Status	Integer	enable disable (disable)	RW	radaccstatus
Accounting Inactivity Timer	Integer32	0 – 2147483647 minutes; default is 5 min.	RW	radaccinactivetmr

Command Line Interface (CLI)

RADIUS Authentication

⇒ NOTE

Use a server name only if you have enabled the DNS Client functionality. See [DNS Client for RADIUS Name Resolution](#).

Name	Type	Values	Access	CLI Parameter
RADIUS Authentication	Table	N/A	R	radiustbl
Primary RADIUS	Integer	1	R	index
Backup RADIUS	Integer	2	R	index
RADIUS Server Status	Integer	enable disable (default)	RW	status
Server Addressing Format (see note)	Integer	ipaddr (default) name	RW	seraddrfmt
Server IP Address or Name	IpAddress DisplayString	User Defined (enter an IP address if seraddrfmt is ipaddr or a name if set to name; up to 254 characters if using a name)	RW	ipaddr
Port (optional)	Integer	User Defined 1812 (default)	RW	port
Shared Secret	DisplayString	User Defined max 63 characters	W	ssecret
Response Time (sec)	Integer	1 – 4 seconds 3 sec (default)	RW	responsetm
Maximum Retransmissions (optional)	Integer	1 – 10 3 (default)	RW	maxretr

RADIUS Accounting

⇒ NOTE

Use a server name only if you have enabled the DNS Client functionality. See [DNS Client for RADIUS Name Resolution](#).

Name	Type	Values	Access	CLI Parameter
RADIUS Accounting	Table	N/A	R	radacctbl
Primary RADIUS	Integer	1	R	index
Backup RADIUS	Integer	2	R	index
RADIUS Server Status	Integer	enable disable (default)	RW	status
Server Addressing Format (see note)	Integer	ipaddr (default) name	RW	seraddrfmt
Server IP Address or Name	IpAddress Display String	User Defined (enter an IP address if seraddrfmt is ipaddr or a name if set to name; up to 254 characters if using a name)	RW	ipaddr
Port (optional)	Integer	User Defined 1813 (default)	RW	port
Shared Secret	DisplayString	User Defined max 63 characters	W	ssecret
Response Time (sec)	Integer	1 – 4 seconds 3 sec (default)	RW	responsetm
Maximum Retransmissions (optional)	Integer	1 – 10 3 (default)	RW	maxretr

Command Line Interface (CLI)

Other Parameters

IAPP Parameters

Name	Type	Values	Access	CLI Parameter
IAPP	Group	N/A	R	iapp
IAPP Status	Integer	enable (default) disable	RW	iappstatus
Periodic Announce Interval (seconds)	Integer	80 120 (default) 160 200	RW	iappannint
Announce Response Time	Integer	2 seconds	R	iappannresp
Handover Time-out	Integer	410 ms 512 ms (default) 614 ms 717 ms 819 ms	RW	iapphandtout
Max. Handover Retransmissions	Integer	1 - 10 (default 4)	RW	iapphandretx
Send Announce Request on Startup	Integer	enable (default) disable	RW	iappannreqstart

NOTE

These parameters configure the Inter Access Point Protocol (IAPP) for roaming. Leave these settings at their default value unless a technical representative asks you to change them.

SpectraLink VoIP Parameters (AP-600b Only)

Name	Type	Values	Access	CLI Parameter
Spectralink VoIP	Group	N/A	R	spectralink
Spectralink VoIP Status	Integer	enable disable (default)	RW	speclinkstatus

B

ASCII Character Chart

You can configure WEP Encryption Keys in either Hexadecimal or ASCII format. Hexadecimal digits are 0-9 and A-F (not case sensitive). ASCII characters are 0-9, A-F, a-f (case sensitive), and punctuation marks. Each ASCII character corresponds to two hexadecimal digits.

The table below lists the ASCII characters that you can use to configure WEP Encryption Keys. It also lists the Hexadecimal equivalent for each ASCII character.

ASCII Character	Hex Equivalent	ASCII Character	Hex Equivalent	ASCII Character	Hex Equivalent	ASCII Character	Hex Equivalent
!	21	9	39	Q	51	i	69
"	22	:	3A	R	52	j	6A
#	23	;	3B	S	53	k	6B
\$	24	<	3C	T	54	l	6C
%	25	=	3D	U	55	m	6D
&	26	>	3E	V	56	n	6E
'	27	?	3F	W	57	o	6F
(28	@	40	X	58	p	70
)	29	A	41	Y	59	q	71
*	2A	B	42	Z	5A	r	72
+	2B	C	43	[5B	s	73
,	2C	D	44	\	5C	t	74
-	2D	E	45]	5D	u	75
.	2E	F	46	^	5E	v	76
/	2F	G	47	_	5F	w	77
0	30	H	48	`	60	x	78
1	31	I	49	a	61	y	79
2	32	J	4A	b	62	z	7A
3	33	K	4B	c	63	{	7B
4	34	L	4C	d	64		7C
5	35	M	4D	e	65	}	7D
6	36	N	4E	f	66	~	7E
7	37	O	4F	g	67		
8	38	P	50	h	68		

C

Specifications

In This Appendix

- [Hardware Specifications](#)
- [Radio Specifications](#)

Hardware Specifications

Physical Specifications

AP-600 Unit (without metal base)

Dimensions (H x W x L) = 3.5 x 17 x 21.5 cm (1.5 x 6.75 x 8.5 in.)
Weight = 0.68 kg (1.50 lb.)

Electrical Specifications

Using the Power Adapter

Voltage (Input) = 100 to 240 VAC (50-60 Hz) @ 0.4 A
Voltage (Output) = 12 VDC
Power Consumption = 10 Watts

Using Active Ethernet

Input Voltage = 42 to 60 VDC
Output Current = 200mA at 48V
Power Consumption = 10 Watts

Environmental Specifications

AP-600 Unit

Operating Temperature = 0° to +55°C ambient temperature (without plastic cabinet)
Operating Humidity = 95% maximum (non condensing)
Storage Temperature = -20 to +75°C ambient temperature
Storage Humidity = 95% maximum (non condensing)

Ethernet Interface

10/100 Base-TX, RJ-45 female socket

Serial Port Interface

Standard RS-232C interface with DB-9, female connector

Specifications

Active Ethernet Interface

Category 5, foiled, twisted pair cables must be used to ensure compliance with FCC Part 15, subpart B, Class B requirements
Standard 802.3af pin assignments

HTTP Interface

Microsoft Internet Explorer 5.5 or later (preferred), or Netscape 4.x or later.

Radio Specifications

For AP-600a: 802.11a radio certification is available in the U.S. (FCC), Canada (DOC), Japan (MKK), Europe (ETSI), Singapore, and Australia.

For AP-600b: 802.11b radio certification is available in the U.S. (FCC), Canada (DOC), Japan (MKK), Europe (ETSI), Australia, and South Africa.

NOTE

Refer to the Regulatory Flyer included with the AP-600 for the latest regulatory information.

802.11a Channel Frequencies for the AP-600a

The available 802.11a Channels varies by regulatory domain and/or country.

FCC (U.S., Canada, Australia)

The AP-600a can operate on the following Channels in the FCC regulatory domain:

Channel ID	Center Frequency (GHz)		Channel ID	Center Frequency (GHz)
36	5.180		60	5.300
40	5.200		64	5.320
42 (see note)	5.210		149	5.745
44	5.220		152 (see note)	5.760
48	5.240		153	5.765
50 (see note)	5.250		157	5.785
52	5.260		160 (see note)	5.800
56	5.280		161	5.805
58 (see note)	5.290		165	5.825

NOTE

Channels 42, 50, 58, 152, and 160 are the available Channels when 2X Turbo mode is enabled. These Channels are unavailable when 2X Turbo mode is disabled.

Specifications

ETSI (Europe)

Some European countries restrict 802.11a operation to the 5.15-5.25 GHz frequency band. Other European countries restrict 802.11a operation to the 5.15-5.35 GHz frequency band.

The AP-600a can operate on the following Channels in the European countries that allow operation in the 5.15-5.25 GHz band:

Channel ID	Center Frequency (GHz)
36	5.180
40	5.200
44	5.220
48	5.240

The AP-600a can operate on the following Channels in the European countries that allow operation in the 5.15-5.35 GHz band:

Channel ID	Center Frequency (GHz)		Channel ID	Center Frequency (GHz)
36	5.180		52	5.260
40	5.200		56	5.280
44	5.220		60	5.300
48	5.240		64	5.320

Japan (MKK)

The AP-600a can operate on the following Channels in Japan:

Channel ID	Center Frequency (GHz)
34	5.170
38	5.190
42	5.210
46	5.230

Singapore

The AP-600a can operate on the following Channels in Singapore:

Channel ID	Center Frequency (GHz)		Channel ID	Center Frequency (GHz)
36	5.180		153	5.765
40	5.200		157	5.785
44	5.220		161	5.805
48	5.240		165	5.825
149	5.745			

Specifications

802.11b Channel Frequencies for the AP-600b

The following table shows the 802.11b channel allocations that vary from country to country.

Channel ID	FCC/World (GHz)	ETSI (GHz)	France (GHz)	Japan (GHz)
1	2.412	2.412	-	2.412
2	2.417	2.417	-	2.417
3	2.422	2.422	-	2.422
4	2.427	2.427	-	2.427
5	2.432	2.432	-	2.432
6	2.437	2.437	-	2.437
7	2.442	2.442	-	2.442
8	2.447	2.447	-	2.447
9	2.452	2.452	-	2.452
10	2.457	2.457	2.457	2.457
11	2.462	2.462	2.462	2.462
12	-	2.467	2.467	2.467
13	-	2.472	2.472	2.472
14				2.484

Specifications

Wireless Communication Range

The range of the wireless signal is related to the composition of objects in the radio wave path and the transmit rate of the wireless communication. Communications at a lower transmit range may travel longer distances. The range values listed in the Communications Range Chart are typical distances as calculated by Proxim's development team for FCC-certified products. These values provide a rule of thumb and may vary according to the actual radio conditions at the location where the product is used.

The range of your wireless devices can be affected when the antennas are placed near metal surfaces and solid high-density materials. Range is also impacted due to "obstacles" in the signal path of the radio that may either absorb or reflect the radio signal.

In Open Office environments, antennas can "see" each other (no physical obstructions between them). In Semi-open Office environments, workspace is divided by shoulder-height, hollow wall elements; antennas are at desktop level. In a Closed Office environment, solid walls and other obstructions may affect signal strength.

The following tables show typical range values for various environments for FCC-certified products (range may differ for products certified in other regulatory domains).

AP-600a

Range	54 Mbits/s	54 Mbits/s	36 Mbits/s	24 Mbits/s	18 Mbits/s	12 Mbits/s	9 Mbits/s	6 Mbits/s
Open Office	44 m (144 ft.)	67 m (220 ft.)	102 m (335 ft.)	155 m (508 ft.)	212 m (695 ft.)	261 m (856 ft.)	290 m (951 ft.)	321 m (1053 ft.)
Semi-Open Office	29 m (95 ft.)	42 m (138 ft.)	60 m (197 ft.)	85 m (279 ft.)	111 m (364 ft.)	132 m (433 ft.)	145 m (475 ft.)	158 m (518 ft.)
Closed Office	21 m (69 ft.)	28 m (92 ft.)	37 m (121 ft.)	49 m (161 ft.)	61 m (200 ft.)	71 m (233 ft.)	76 m (250 ft.)	82 m (269 ft.)
Receiver Sensitivity	-69 dBm	-73 dBm	-77 dBm	-81 dBm	-84 dBm	-86 dBm	-87 dBm	-88 dBm

Table C-1 AP-600a: 802.11a Wireless communication ranges



NOTE

The typical range values for 2X Turbo mode are similar to the values listed above. For example, the operating range at 108 Mbits/sec in 2X Turbo mode is similar to the operating range at 54 Mbits/sec in 802.11a mode.

AP-600b

Range	11 Mbits/s	5.5 Mbits/s	2 Mbits/s	1 Mbits/s
Open Office	253 m (830 ft.)	347 m (1138 ft.)	475 m (1558 ft.)	650 m (2132 ft.)
Semi-Open Office	129 m (423 ft.)	168 m (551 ft.)	220 m (722 ft.)	286 m (938 ft.)
Closed Office	69 m (226 ft.)	86 m (282 ft.)	107 m (351 ft.)	132 m (433 ft.)
Receiver Sensitivity	-82 dBm	-85 dBm	-88 dBm	-91 dBm

Table C-2 AP-600b: 802.11b Wireless communication ranges

D

Technical Support

If you are having a problem using an AP-600 and cannot resolve it with the information in [Troubleshooting](#), gather the following information and contact ORiNOCO Technical Support:

- List of ORiNOCO products installed on your network; include the following:
 - Product names and quantity
 - Part numbers (P/N)
 - Serial numbers (S/N)
- List of ORiNOCO software versions installed
 - For the AP-600, check the HTTP interface's [Version](#) screen
 - Include the source of the software version (e.g., pre-loaded on unit, installed from CD, downloaded from Proxim Web site, etc.)
- Information about your network
 - Network operating system (e.g., Microsoft Networking); include version information
 - Protocols used by network (e.g., TCP/IP, NetBEUI, IPX/SPX, AppleTalk)
 - Ethernet frame type (e.g., 802.3, Ethernet II), if known
 - IP addressing scheme (include address range and whether static or DHCP)
 - Network speed and duplex (10 or 100 Mbits/sec; full or half duplex)
 - Type of Ethernet device that the Access Points are connected to (e.g., Active Ethernet power injector, hub, switch, etc.)
 - Type of Security enabled on the wireless network (None, WEP Encryption, 802.1x, Mixed)
- A description of the problem you are experiencing
 - What were you doing when the error occurred?
 - What error message did you see?
 - Can you reproduce the problem?
 - For each ORiNOCO product, describe the behavior of the device's LEDs when the problem occurs

You can reach ORiNOCO Technical Support by phone or e-mail, as described below.

NOTE

The latest software and documentation is available for download at <http://www.proxim.com>.

For the U.S. and Canada:

Phone: 1-866-ORiNOCO (1-866-674-6626)
E-mail: USAsupport@orinocowireless.com

For the Caribbean and Latin America:

Phone: 1-866-ORiNOCO (1-866-674-6626)
1-661-367-2230
E-mail: CALAsupport@orinocowireless.com

Technical Support



For Asia Pacific:

Phone: +1 661-367-2230
E-mail: APACsupport@orinocowireless.com

For Europe, the Middle East, and Africa (EMEA):

Your local supplier in the EMEA region is trained to give you the support you require. Local suppliers have direct access to the ORINOCO Technical Support Center and will help you in every way they can.

Phone: +1 661-367-2230
E-mail: EMEAsupport@orinocowireless.com